

For New Technology Network

NTN[®]

NTN corporation

CONSTANT VELOCITY JOINTS

for industrial machines

CAT. No. 5603-VA/E



Warranty

NTN warrants, to the original purchaser only, that the delivered product which is the subject of this sale (a) will conform to drawings and specifications mutually established in writing as applicable to the contract, and (b) be free from defects in material or fabrication. The duration of this warranty is one year from date of delivery. If the buyer discovers within this period a failure of the product to conform to drawings or specifications, or a defect in material or fabrication, it must promptly notify NTN in writing. In no event shall such notification be received by NTN later than 13 months from the date of delivery. Within a reasonable time after such notification, NTN will, at its option, (a) correct any failure of the product to conform to drawings, specifications or any defect in material or workmanship, with either replacement or repair of the product, or (b) refund, in part or in whole, the purchase price. Such replacement and repair, excluding charges for labor, is at NTN's expense. All warranty service will be performed at service centers designated by NTN. These remedies are the purchaser's exclusive remedies for breach of warranty.

NTN does not warrant (a) any product, components or parts not manufactured by NTN, (b) defects caused by failure to provide a suitable installation environment for the product, (c) damage caused by use of the product for purposes other than those for which it was designed, (d) damage caused by disasters such as fire, flood, wind, and lightning, (e) damage caused by unauthorized attachments or modification, (f) damage during shipment, or (g) any other abuse or misuse by the purchaser.

THE FOREGOING WARRANTIES ARE IN LIEU OF ALL OTHER WARRANTIES, EXPRESS OR IMPLIED, INCLUDING BUT NOT LIMITED TO THE IMPLIED WARRANTIES OF MERCHANTABILITY AND FITNESS FOR A PARTICULAR PURPOSE.

In no case shall NTN be liable for any special, incidental, or consequential damages based upon breach of warranty, breach of contract, negligence, strict tort, or any other legal theory, and in no case shall total liability of NTN exceed the purchase price of the part upon which such liability is based. Such damages include, but are not limited to, loss of profits, loss of savings or revenue, loss of use of the product or any associated equipment, cost of capital, cost of any substitute equipment, facilities or services, downtime, the claims of third parties including customers, and injury to property. Some states do not allow limits on warranties, or on remedies for breach in certain transactions. In such states, the limits in this paragraph and in paragraph (2) shall apply to the extent allowable under case law and statutes in such states.

Any action for breach of warranty or any other legal theory must be commenced within 15 months following delivery of the goods.

Unless modified in a writing signed by both parties, this agreement is understood to be the complete and exclusive agreement between the parties, superceding all prior agreements, oral or written, and all other communications between the parties relating to the subject matter of this agreement. No employee of NTN or any other party is authorized to make any warranty in addition to those made in this agreement.

This agreement allocates the risks of product failure between NTN and the purchaser. This allocation is recognized by both parties and is reflected in the price of the goods. The purchaser acknowledges that it has read this agreement, understands it, and is bound by its terms.

© NTN Corporation. 2005

Although care has been taken to assure the accuracy of the data compiled in this catalog, NTN does not assume any liability to any company or person for errors or omissions.

NTN Constant Velocity Joints

for Industrial Applications

Outline	Types and Features	P 2~
	Type Selection Flowchart	P 3~
	Structure	P 4~
	Joint Selection	P12~
Dimensions Table	Fixed Disc Type	P23~
	Fixed Cup Type	P29~
	Sliding Type	P33~
	Coupling Type	P39~
Accessories	P44~	
Diagrams of Applications	P48~	
Usage and Handling	P50~	
Service Conditions Confirmation Sheet	P61~	

Types and Features

- Rotational speed can be transmitted at constant velocity
- Greater torque capacity
- Long service life and high reliability
- High transmission efficiency
- Low secondary moment
- Smooth and quiet rotation
- Easy handling, with long lubrication life requiring infrequent re-rubrication

Table 1. Types and features of NTN constant velocity joint

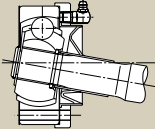
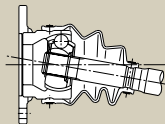
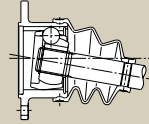
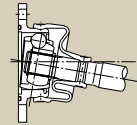
Variety	Type	CVJ number	Max. allowable operating angle ^①	Features	
Fixed type	Disc type		BJ75D–BJ300D	14° to 18°	Capable of high speed operation. No need for intermediate slide spline shaft.
	Cup type		BJ75C–BJ225C	25°	Greater operating angle. Excellent sealing.
Sliding type	Flange type		DOJ 68F–DOJ200F	20°	Expansion within joint is possible. Low sliding friction (expansion friction).
			DOJ225F–DOJ625F	8° to 10°	
Coupling type	Short shaft series Long shaft series		BC68–BC200 ^②	5°	No alignment is needed. Easy installation.

① The maximum allowable operating angle is limited by a boot, as well as the RPM and operating conditions of the CVJ assembly.

② Upon request from the user, larger sizes can be designed and manufactured. Contact NTN Engineering.

Remarks: The NTN constant velocity joint range includes, in addition to those listed here, the bell type CVJs used for drive shafts of automobiles (passenger cars, trucks), construction vehicles and special vehicles, and the NTN proprietary TRI-BALL joint that features unique structure and functions.

Type Selection Flowchart

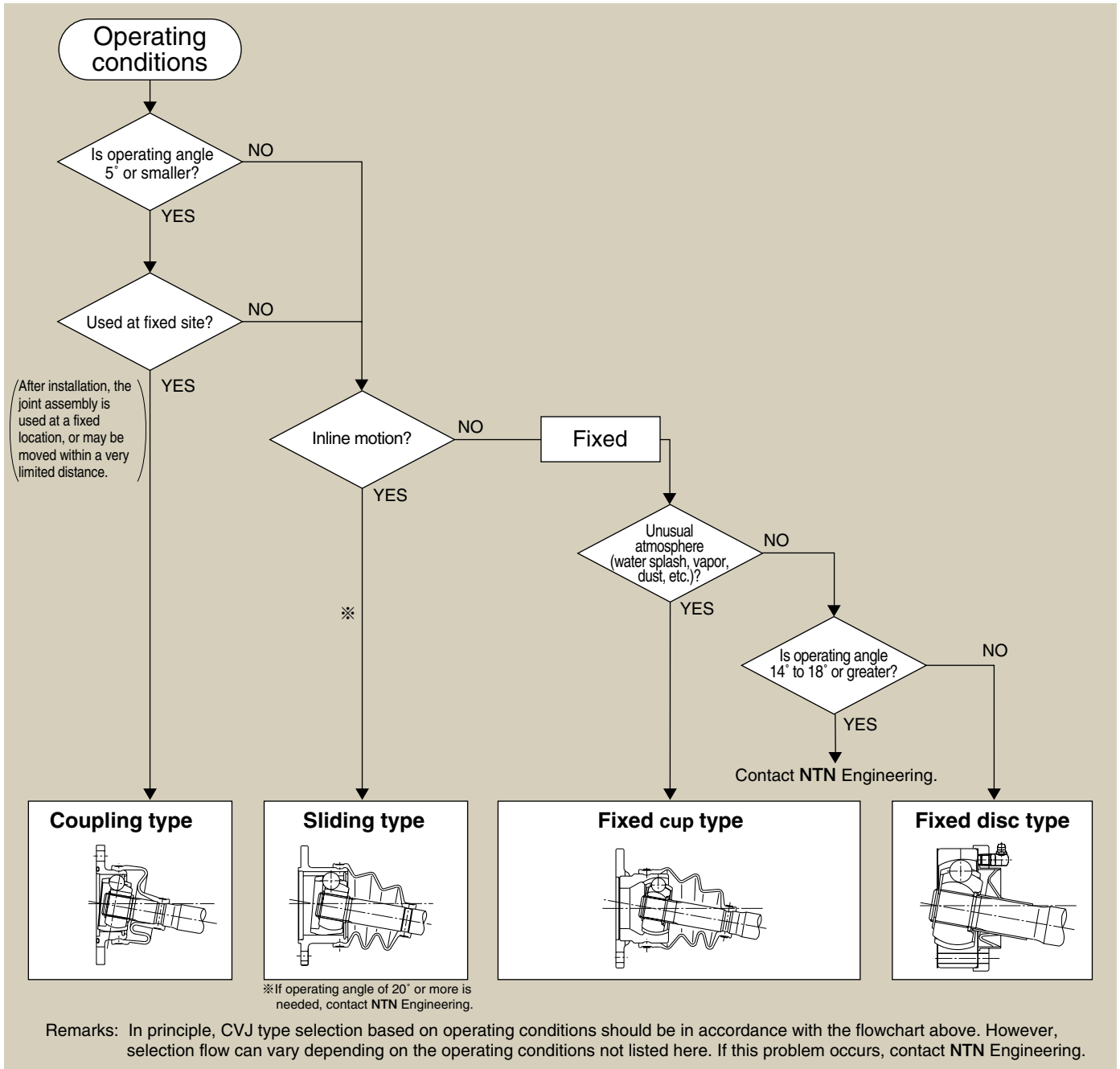

Applications

Coupling type	Sliding type	Fixed cup/drum type	Fixed disc type
To compensate for shaft offset with general industrial plant machinery. Connecting shafts of motors on reducer, neck pinion, pump, blower, compressor, hearth roller, conveyor, refiner, crane, hydraulic unit, etc.	Drive shafts of work rolls, pinch rolls, tension reels in rolling mill (steel making machinery). Drive shafts of calender rolls (paper making machinery) and of other general industrial machines (in areas where expansion is needed during driving). Drive shafts of automobiles (passenger cars, trucks) and special vehicles. Hydraulic pump drive shafts of steel making machinery and chemical machinery. Hydraulic pump drive shafts of construction machinery.	Hydraulic pump drive shafts of truck mixers. Drive shafts of hygiene, food processing and packaging machines. Other general industrial plant machinery (where larger operating angle is needed). Tiller drive shafts of agricultural tractors. Drive shafts of machine tools and printing presses. Other general industrial machines (where larger operating angle is needed).	Drive shafts of steel making machinery, paper making machinery, printing machinery, unloading/transportation machinery, textile machinery, chemical machinery, machine tools and other general industrial machines.

Structure

Fixed Disc Type

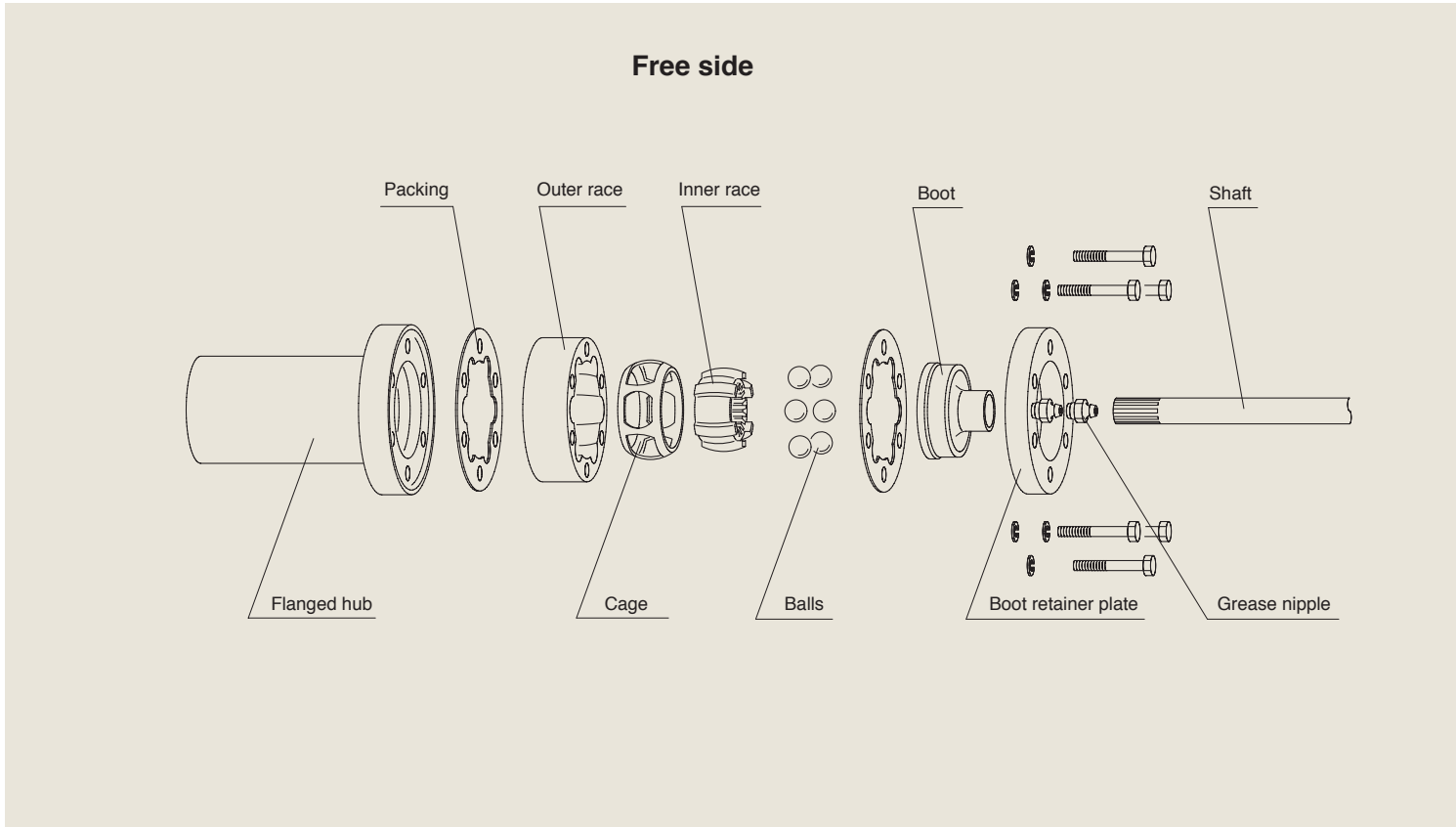

Features

Greater allowable operating angle

Though varying depending on the CVJ size and intended RPM, the maximum allowable operating angle of this type of joint is 18° with boot.

No slide splines are needed for the intermediate shaft

The intermediate shaft does not need slide splines since the axial expansion and installation mounting distance adjustment are achieved by the sliding splines of the inner race and shaft at the free side.

Shorter shaft length

The intermediate shaft can be designed to be much shorter since it does not need slide splines.

Capable of high-speed rotation

The solid shafts for high-speed joints have been precision-machined and the steel pipe shafts have been dynamically balance.

Higher level of safety

A cylindrical outside surface means that while handling, the fingers of worker are not pinched with the yoke.

Remarks:

1. If the maximum allowable operating angle is exceeded, use a cup type joint.
2. If this type of application is unavoidable, use a sliding type joint, or combine a fixed disc type joint with a slide type joint. For types and their combination, contact NTN Engineering.
3. **The disc type joint** is not fully sealed. We recommend that a cup or coupling type joint be used in locations subject to water splash.
4. Certain applications may need much larger axial expansion. To cope with such a need, we can supply a joint with intermediate slide splines. Contact NTN Engineering.

CAUTION

1. The free side CVJ can come off the splined shaft. Be very careful when handling it.
2. Retighten hexagon headed bolts as necessary because the CVJ is fixed by them and they may loosen during operation.

Fixed side

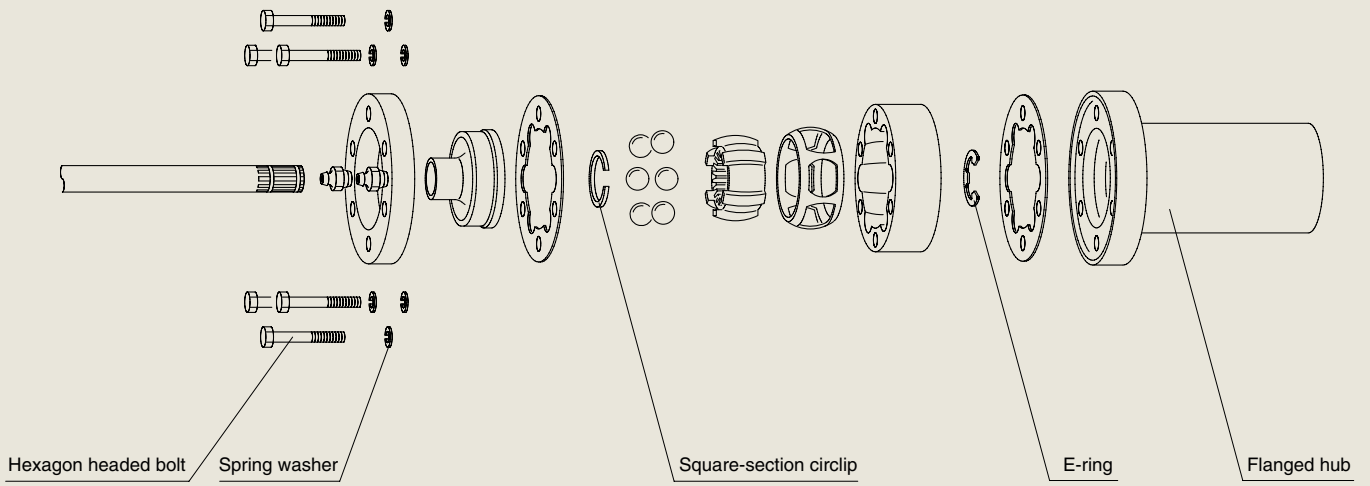

Fixed Cup Type

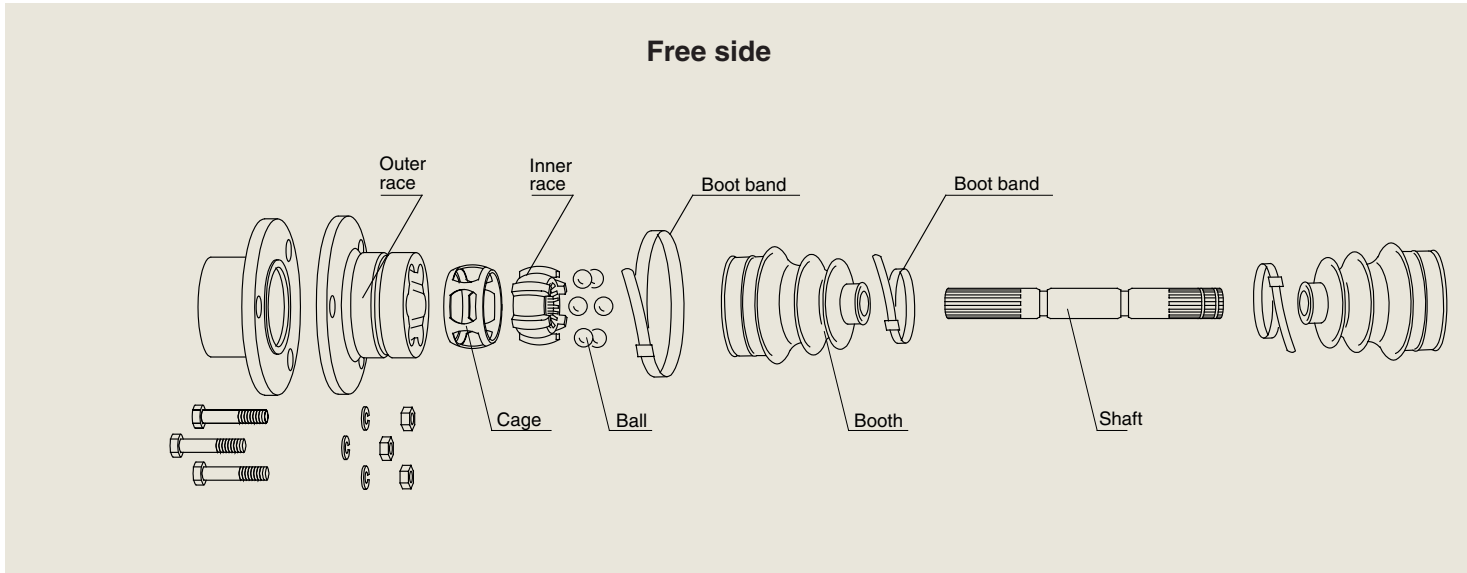

Features

Greater allowable operating angle

The maximum allowable operating angle with the CVJ proper is 42°.

Though varying depending on the intended RPM, the maximum allowable operating angle of the joint equipped with a boot is 25° at dynamic state, and 38° at static state.

Superb sealing, and lubrication-free

Being sealed with bellows type boots, the CVJs can be used in environments where they may be frequently subjected to water splash, humidity and dust.

Greater expansion

The CVJs with intermediate slide spline shaft offer greater axial expansion.

Easy installation and removal

The CVJ proper is secured to the flange hub with through bolts. Thus, the joint can be readily installed or removed.

Remarks:

1. This type is not suitable for use under a situation where an expansion motion occurs while the joint is revolving. If this type of application is unavoidable, use a sliding type joint, or combine a fixed cup type joint with a sliding type joint. For types and their combination, contact NTN Engineering.
2. Consider use of a coupling type joint when the joint assembly is employed for high speed application with a smaller operating angle.

CAUTION

1. The intermediate splined shaft of CLT and CLFT series can come out of position. Be very careful when handling it.

Fixed side

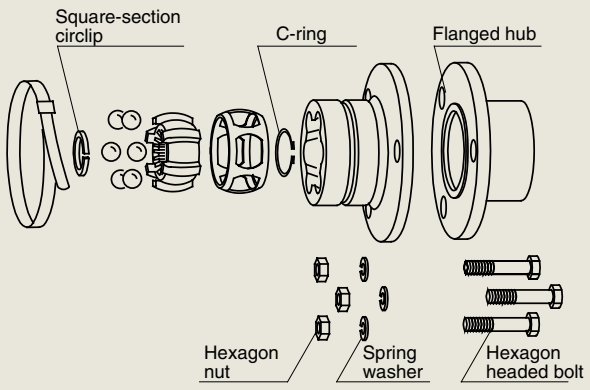

Sliding Type

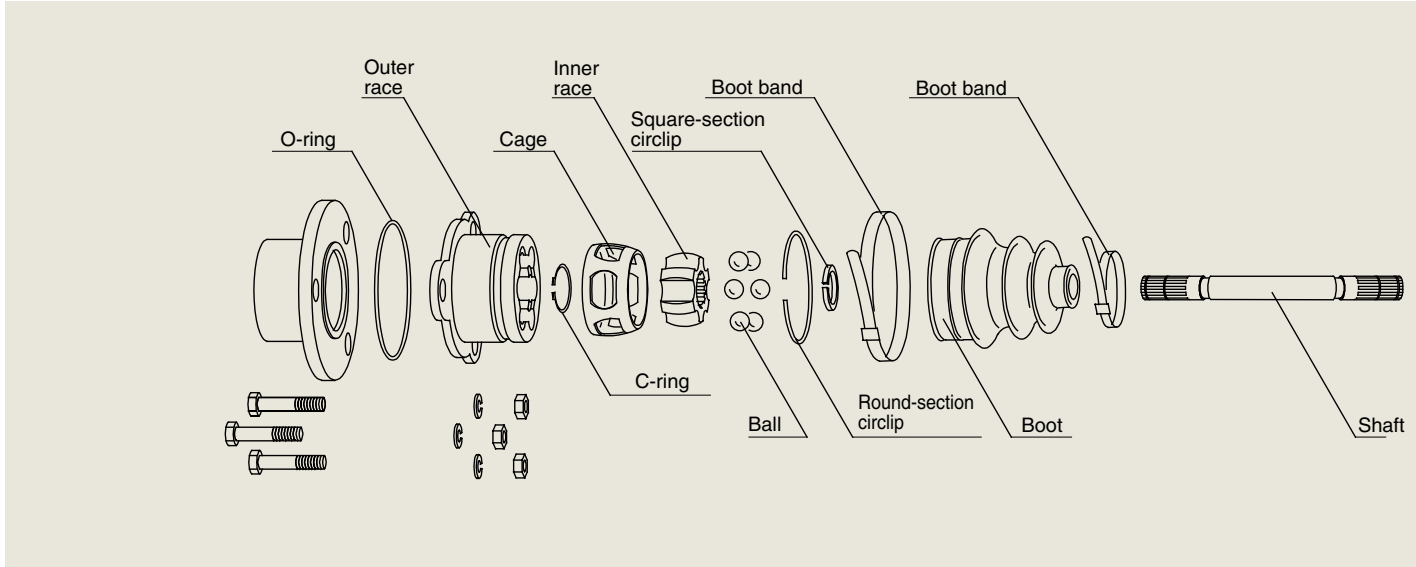

Features

Expansion is possible within CVJ

The ball tracks on the outer race are parallel with the axis. Therefore, relative axial expansion between the inner ring and outer ring is possible while transmitting power and providing an operating angle.

Low sliding friction ensures smooth expansion

Expansion within the CVJ is achieved by a rolling motion of the balls, which contributes to very small sliding friction (expansion-induced friction). As a result, the joint assembly can smoothly plunge even when torque is applied.

The sliding friction of this arrangement is greatly reduced as compared with generic slide spline shaft. (See Fig. 1.)

Axial vibration can be absorbed

Because of the smaller sliding friction, axial vibration can be easily absorbed as compared with the slide spline arrangement.

No slide splines are needed for the intermediate shaft

The intermediate shaft does not need slide splines since the axial expansion and installation mounting distance adjustment are achieved by the structure inside the CVJs.

Easy installation

Both axial expansion and operating angle definition (20° for smaller size, 8° to 10° for larger size) can be achieved simultaneously. Therefore, this type of joint can accommodate a larger length variation, allowing easy installation.

Freedom for wide variety of design

The CVJ assembly can be designed to best suit the user's requirements in terms of torque capacity, expansion and installation system.

Remarks:

1. For the best operation of a sliding type joint, the operating angle-expansion correlation, operating method and installation/removal method should be considered. For details, contact NTN Engineering.
2. If much larger axial expansion is needed, contact NTN Engineering.
3. Some large size CVJs are capable of allowable maximum operating angle of 15°.
4. If the user wants to use the sliding type joint assembly in a vertical position, contact NTN Engineering.

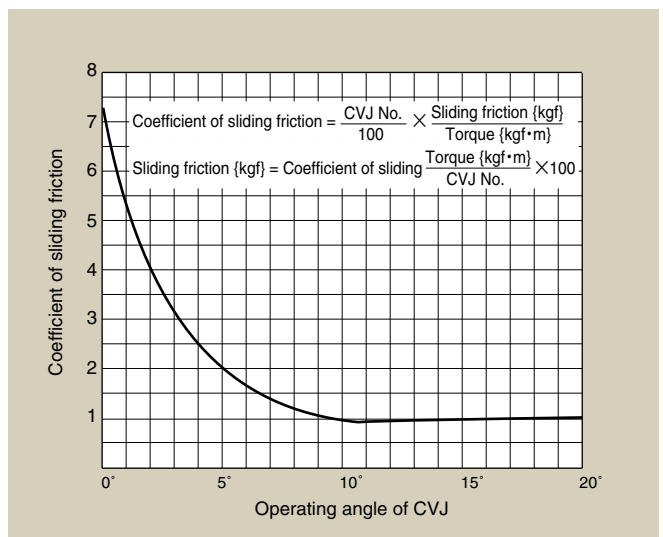
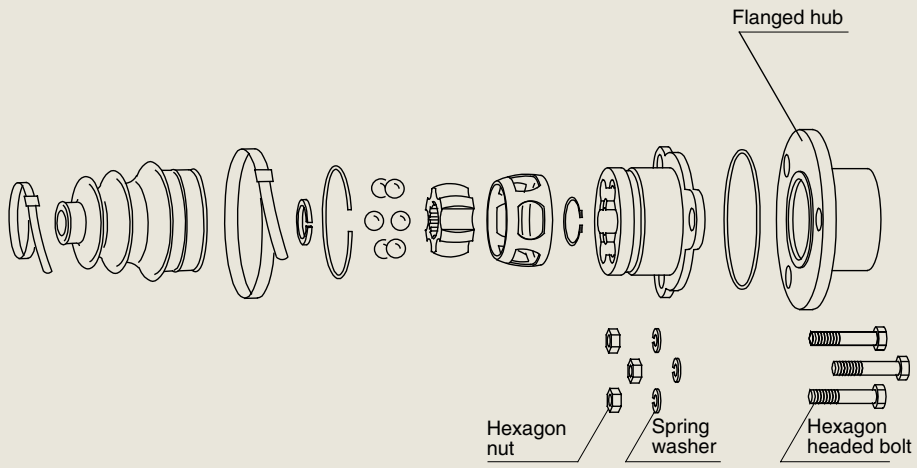
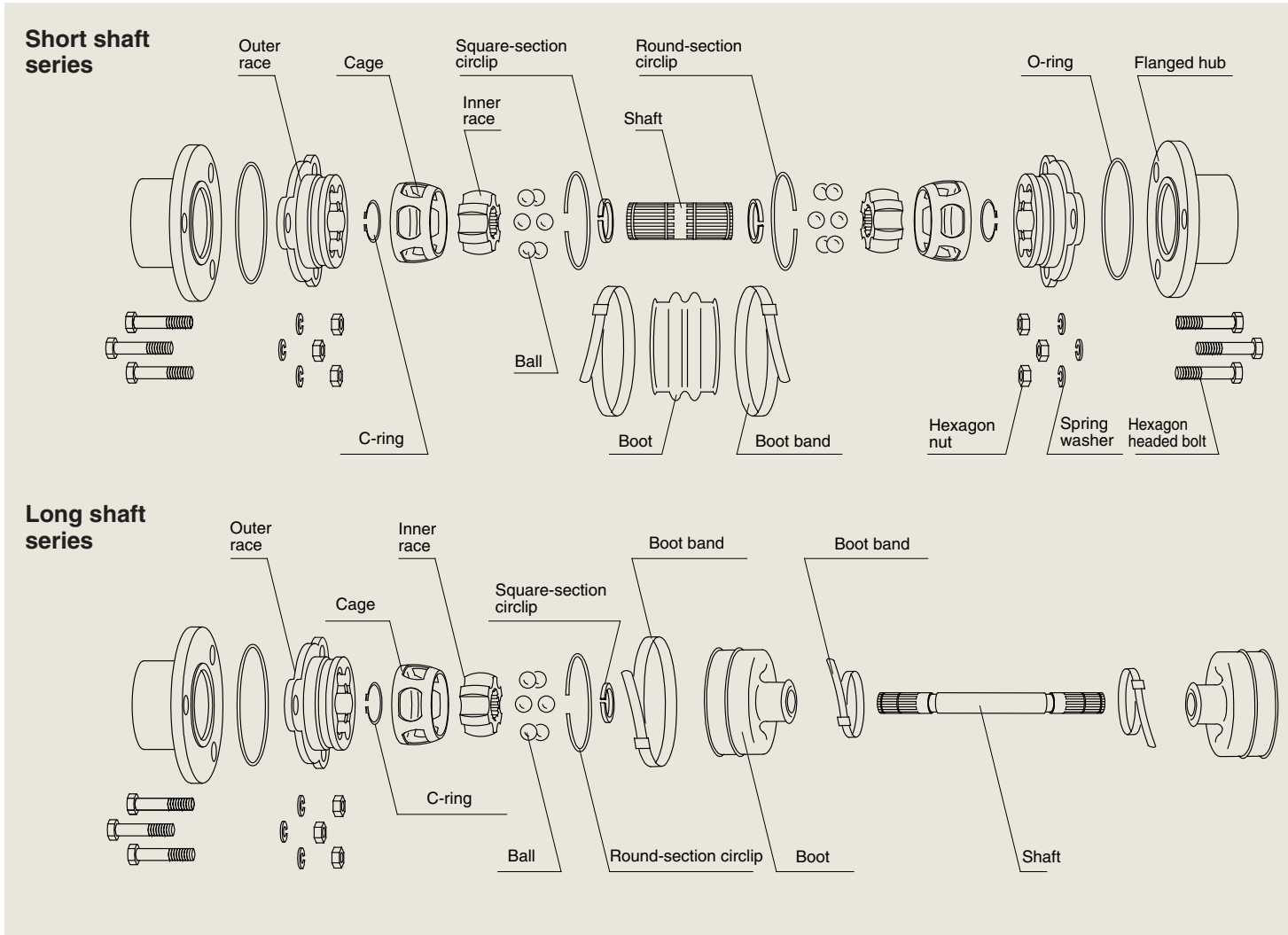

Fig. 1 Sliding friction



Coupling Type



Features

No alignment work is necessary.

The offset across both shafts when the coupling is installed is 3.5 to 11.5 mm in the case of short shaft series joints (see Fig. 1). The long shaft series joints offer much larger offset (see Fig. 3).

The maximum crossed angle between two shafts is 5°. Furthermore, this type of joint allows inline expansion. As a result, time-consuming alignment work is eliminated.

Low sliding friction ensures smooth expansion.

The ball tracks on the outer race are parallel with the axis. Therefore, axial expansion within the CVJs is possible.

Expansion within the joints is achieved by rolling motion of the balls, which contributes to very small sliding friction (expansion-induced friction). As a result, axial vibration can be readily absorbed as compared with generic slide spline arrangement.

Light-weight and compact arrangement that contributes to smaller moment of inertia.

The couplings are relatively small. Also, when a long intermediate shaft is needed, the middle portion of the shaft is composed of steel pipe. This light-weight configuration contributes to smaller moment of inertia, resulting in lower starting/braking torque.

Easy installation

Both flanged hubs are installed to the mating shafts. Then, the couplings are fastened to flanged hubs with bolts.

Since the couplings can be separated from the flanged hubs, the couplings can be fastened after installing a machine in position. Furthermore, installation work is very easy thanks to a larger allowable offset and crossed angle of the couplings.

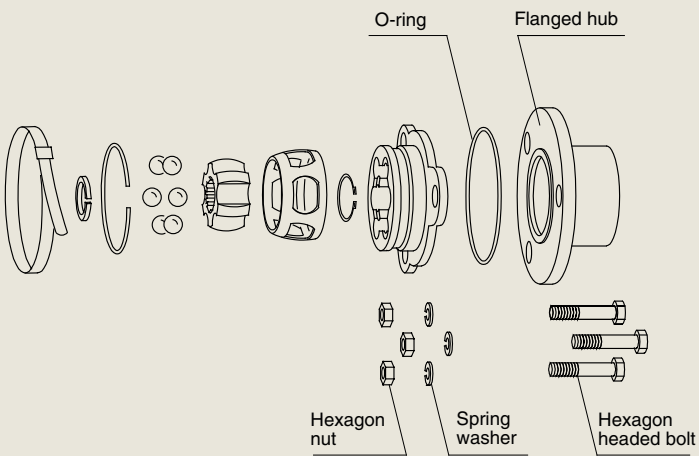

Remarks:

1. If larger axial expansion is needed, consider sliding type joints.
2. If the user wants to use the sliding type joint assembly in a vertical position, contact NTN Engineering.

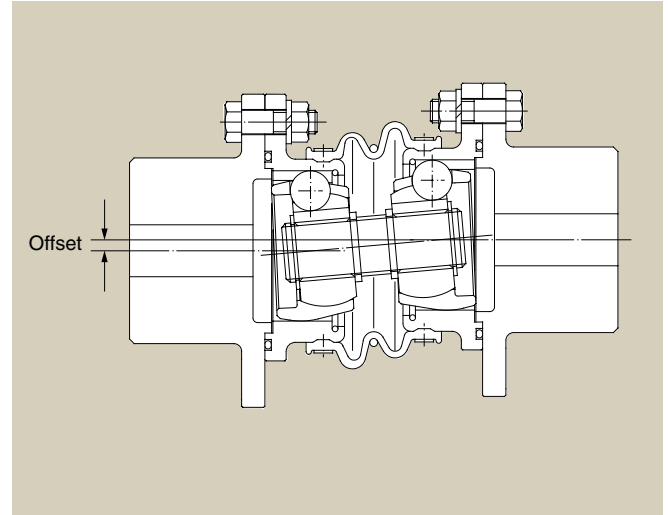

Fig. 1 Short shaft series

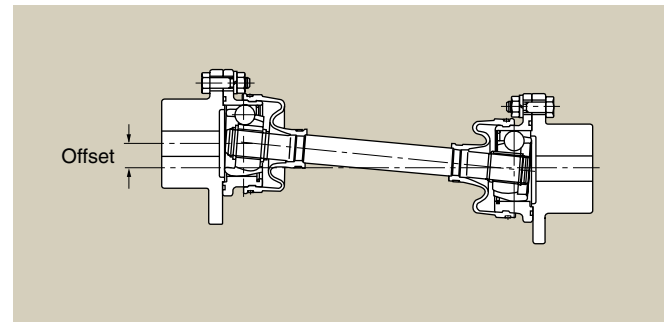

Fig. 2 Long shaft series

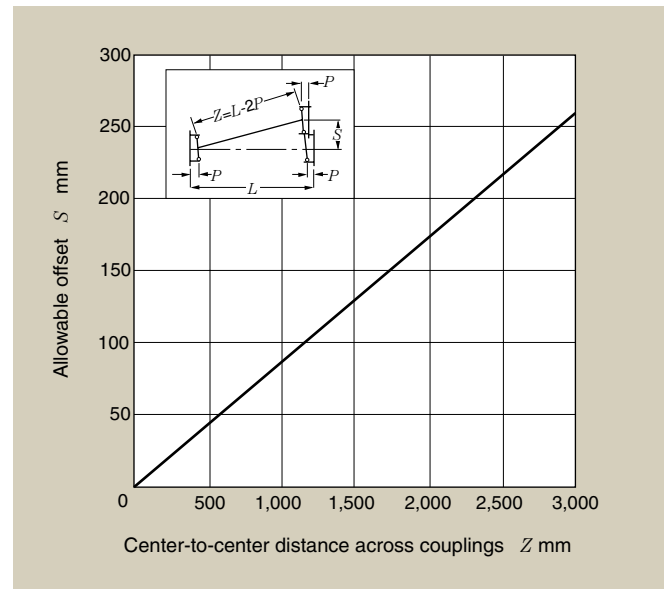

Fig. 3

Joint Selection

1. Selection Based on Service Life

1.1 By referring to the load models in Fig. 1, determine normal working torque T_a {kgf·m} or power Q_a {kW}.

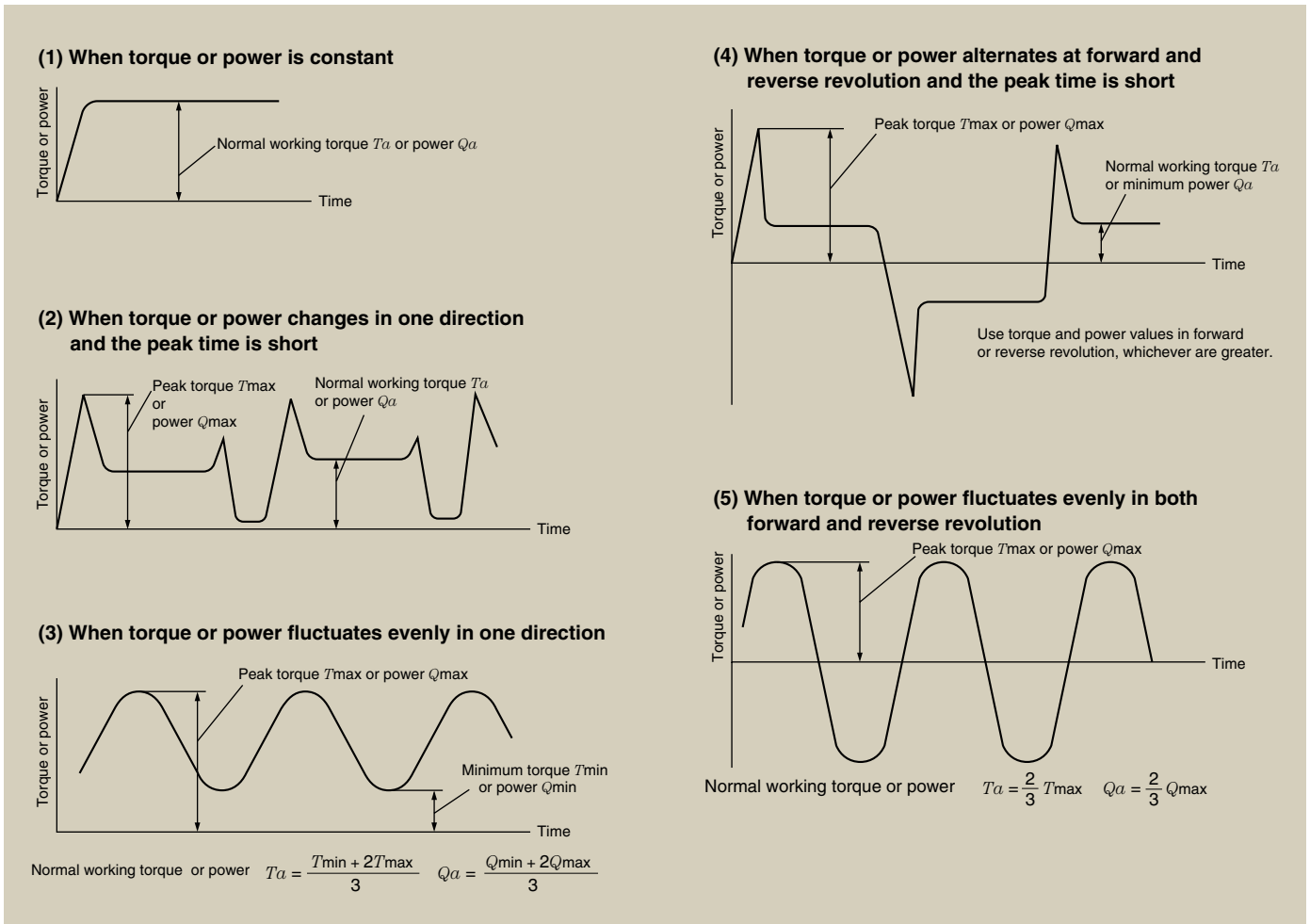

Fig. 1 Load models

1.2 Using the expression below, determine equivalent working torque T_a {kgf·m} or equivalent working transmission power Q_a {kW}.

$$T_e = \frac{K_1 \cdot K_2}{K_3} \cdot T_a \quad \text{or} \quad Q_e = \frac{K_1 \cdot K_2}{K_3} \cdot Q_a$$

where

K_1 : Machine factor (Table 1)

K_2 : Operating time factor (Fig. 2, Fig. 4, Fig. 6)

K_3 : Operating angle factor (Fig. 3, Fig. 5, Fig. 7)

Table 1 Machine factor K_1

Machine used		K_1	
Motor	Electric motor, turbine	1	
	Gasoline engine	4-cylinder or over	1.25
		3-cylinder or less	1.5
	Diesel engine	4-cylinder or over	2
3-cylinder or less		3	
Driven machine	Machine developing strong vibration or impact (crusher, screening machine, etc.)	3	
	Machine running continuously at a constant speed and developing minor vibration (storage/drainage pump, blower, etc.)	1.5	

① Use the factor with the motor or driven machine, whichever is greater.

② The joints may be broken by the twisting resonance, when they are directly coupled to reciprocating engines or plunger pumps. Use these configurations after checking the resonance RPM of the twisting vibration for the driving mechanism.

Fixed Disc/Cup Type

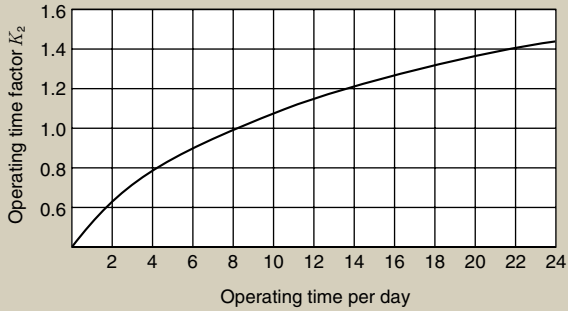

Fig. 2 Operating time factor K_2

Sliding Type

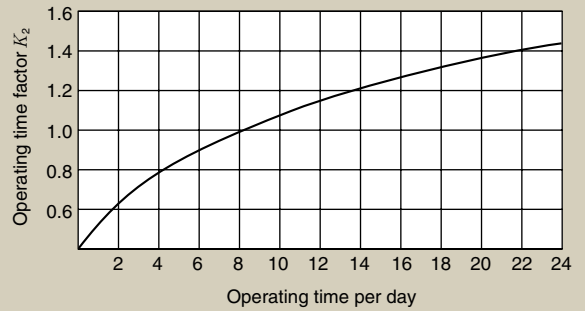

Fig. 4 Operating time factor K_2

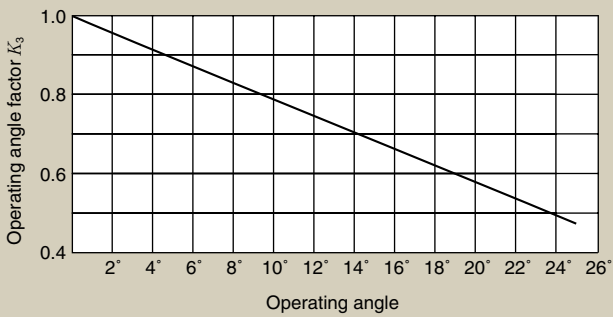

Fig. 3 Operating angle factor K_3

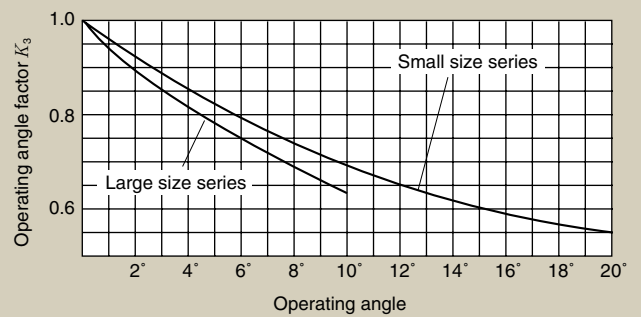

Fig. 5 Operating angle factor K_3

Coupling Type

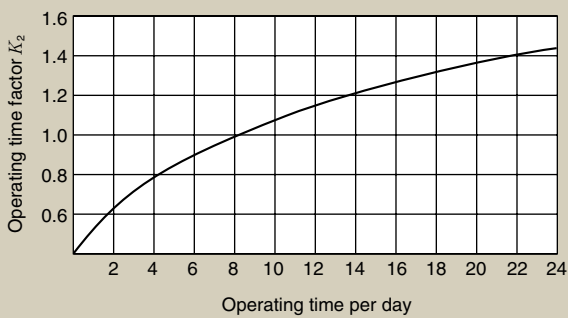

Fig. 6 Operating time factor K_2

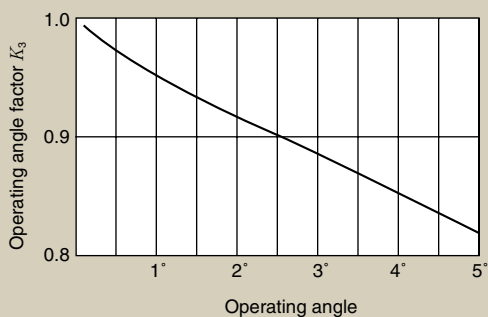
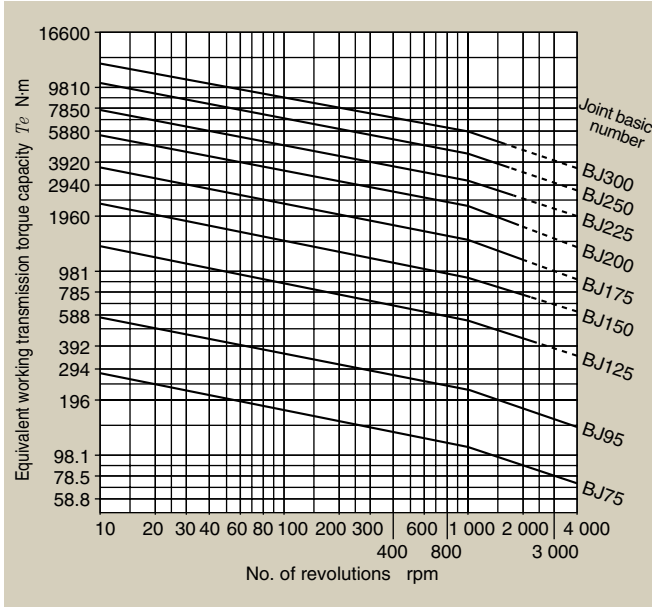

Fig. 7 Operating angle factor K_3

Outline

- 1.3 By referring to the equivalent working transmission torque or power graph in **Fig. 8**, find a CVJ basic number whose capacity at the operating RPM is greater than the equivalent working torque T_e or equivalent working transmission power Q_e determined in 1.2.

Fixed Disc Type



(A) Equivalent working transmission torque capacity

Fixed Cup Type

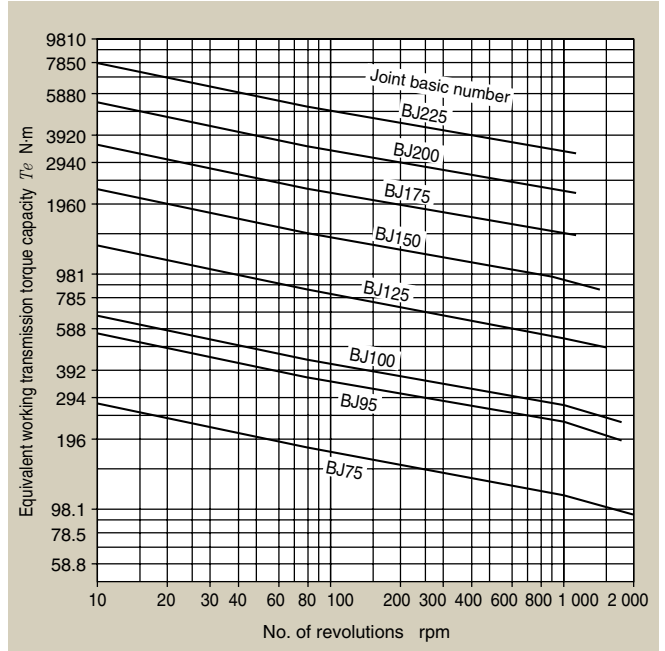

(A) Equivalent working transmission torque capacity

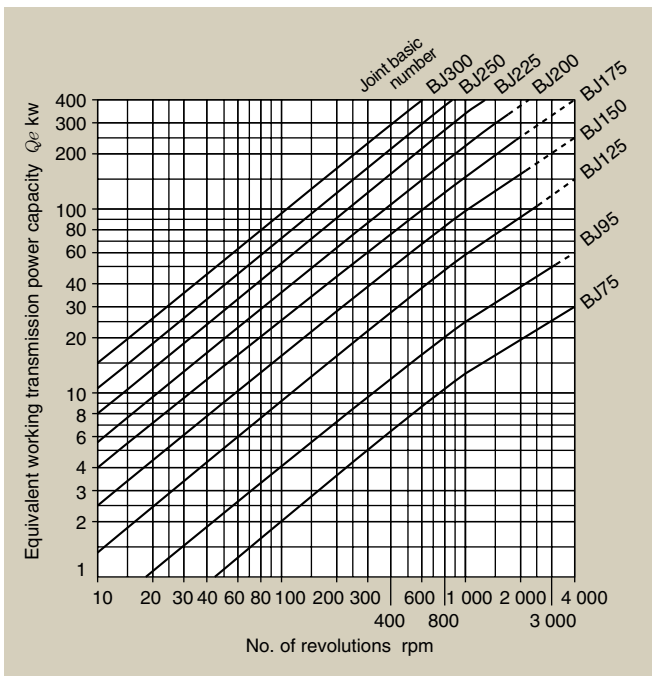

(B) Equivalent working transmission power capacity

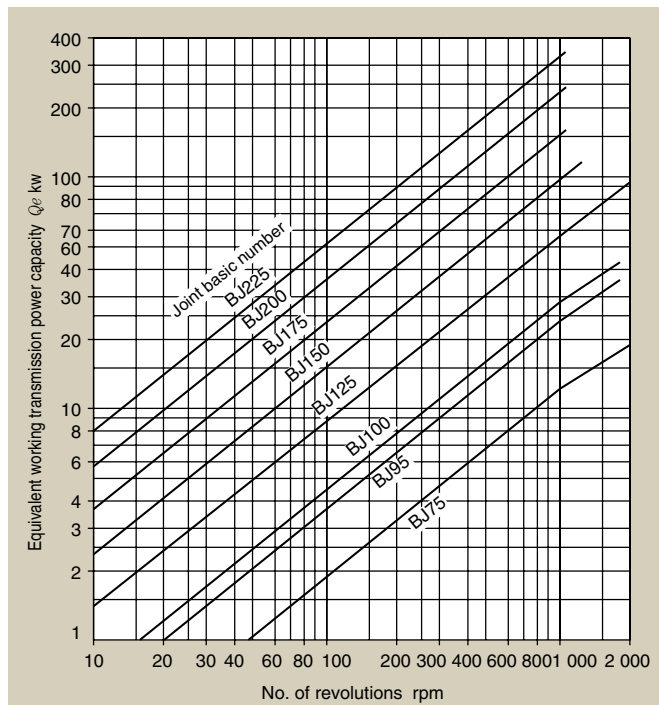

(B) Equivalent working transmission power capacity

Fig. 8-1 Equivalent working transmission torque and equivalent working transmission power capacity

Sliding Type

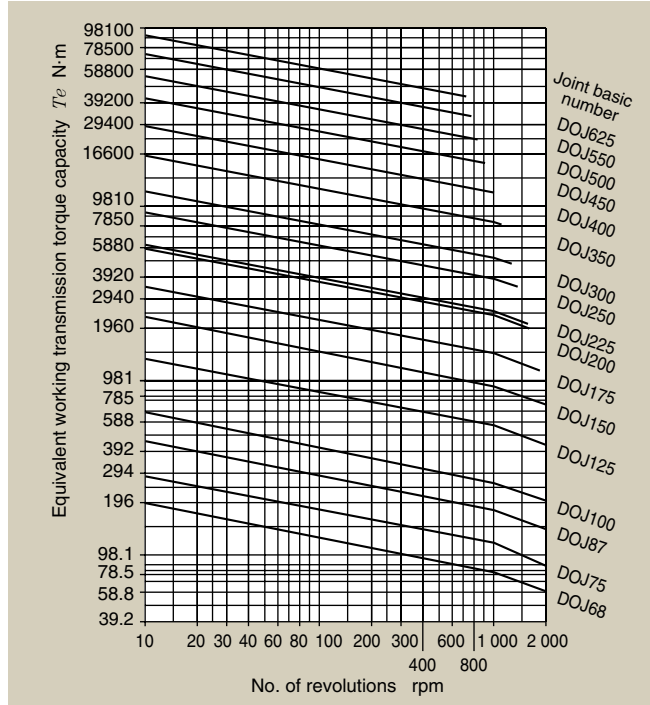

(A) Equivalent working transmission torque capacity

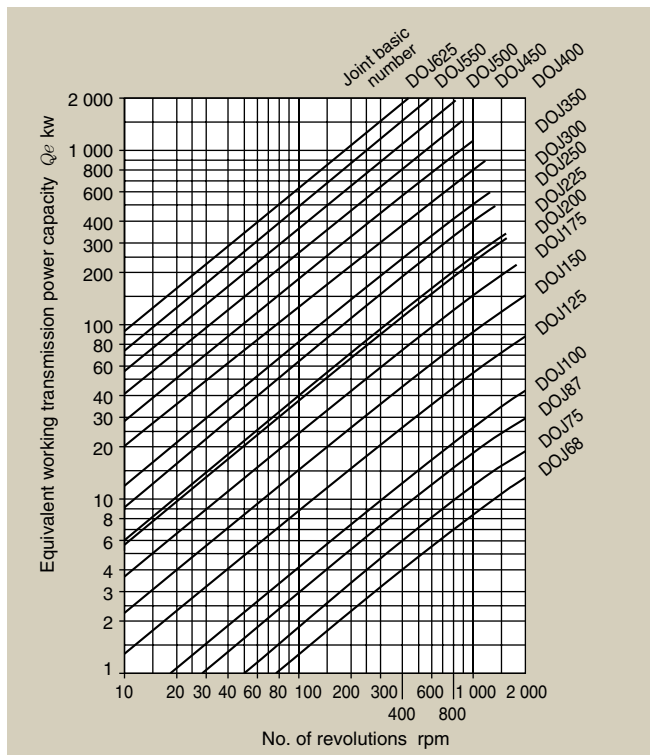

(B) Equivalent working transmission power capacity

- Remarks 1) The values of the equivalent working transmission torque and power in **Fig.8 (A) and (B)** are based on the life of 7,200 hours (three years, 25 working days per month).
 2) When intending to use the CVJ within an envelope defined with a dotted line, contact NTN Engineering.

Coupling Type

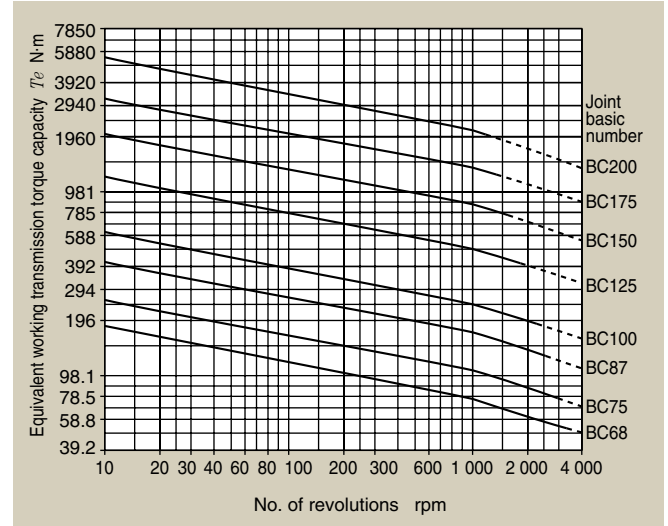

(A) Equivalent working transmission torque capacity

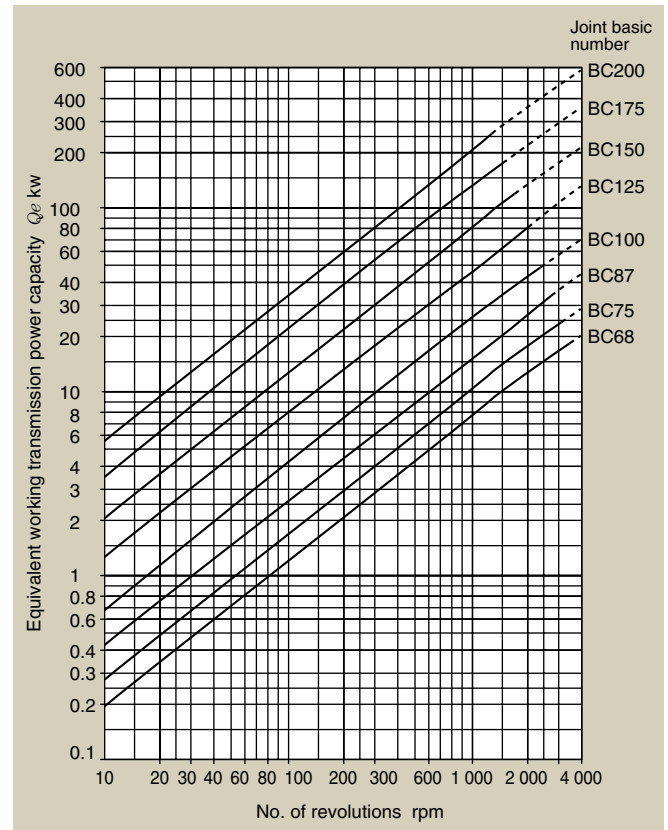

(B) Equivalent working transmission power capacity

Fig. 8-2 Equivalent working transmission torque and equivalent working transmission power capacity

2. Selection Based on Strength

2.1 Determine working peak torque T_{max} {kgf·m}.

2.2 Check that the maximum dynamic allowable torque TD_1 or TD_2 (see **Table 2**) is greater than the working peak torque.

Table 2 Allowable maximum torque of CVJ

Joint basic	Type	Dynamic allowable torque	
		When torque fluctuates during revolution in one direction	When start / stop and forward / reverserevolution are repeated frequently
		TD_1 N·m {kgf·m}	TD_2 N·m {kgf·m}
BC68	Coupling Type	412 {42}	275 {28}
DOJ68	Sliding Type		
BJ75	Fixed Disc Type	588 {60}	392 {40}
	Fixed Cup Type		
DOJ75	Sliding Type		
BC75	Coupling Type	932 {95}	637 {65}
DOJ87	Sliding Type		
BC87	Coupling Type		
BJ95	Fixed Disc Type	1130 {115}	637 {65}
	Fixed Cup Type		
BJ100	Fixed Cup Type	1420 {145}	883 {90}
DOJ100	Sliding Type		
BC100	Coupling Type		
BJ125	Fixed Disc Type	2750 {280}	1470 {150}
	Fixed Cup Type		
DOJ125	Sliding Type		
BC125	Coupling Type	4710 {480}	2890 {295}
BJ150	Fixed Cup Type		
DOJ150	Sliding Type		
BC150	Coupling Type	4810 {490}	4020 {410}
BJ175	Fixed Disc Type	6720 {685}	
	Fixed Cup Type		
DOJ175	Sliding Type	7360 {750}	5880 {600}
BC175	Coupling Type		
BJ200	Fixed Disc Type	11200 {1140}	
	Fixed Cup Type		
DOJ200	Sliding Type	11500 {1170}	7550 {770}
BC200	Coupling Type		
BJ225	Fixed Disc Type	14700 {1500}	7160 {730}
	Fixed Cup Type		
DOJ225	Sliding Type	—	10700 {1090}
BJ250	Fixed Disc Type	20700 {2110}	
DOJ250	Sliding Type	—	11200 {1140}
BJ300	Fixed Disc Type	29100 {2970}	15800 {1610}
DOJ300	Sliding Type	—	14500 {1480}
DOJ350			22900 {2340}
DOJ400			34100 {3480}
DOJ450			48500 {4950}
DOJ500			66800 {6810}
DOJ550			89100 {9090}
DOJ625			116000 {11800}

3. Selection Based on Number of Revolutions

Fixed Disc Type

1. Considering durability of the boots, check that the RPM in Fig. 9 is within the joint angle limitation.

2. Depending on the shaft length, the working RPM of a joint will be limited. Check the allowable RPM of the intended shaft against the data in Fig. 10.

3. For the allowable RPM of the intended shaft in low speed and high speed applications, refer to Fig. 11.

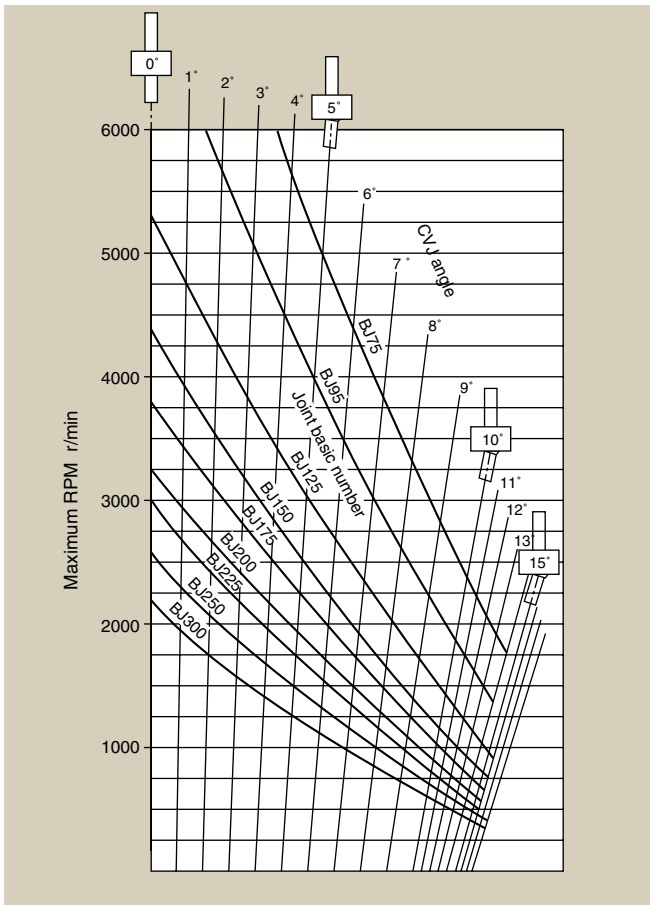

Fig. 9 CVJ angle versus allowable RPM

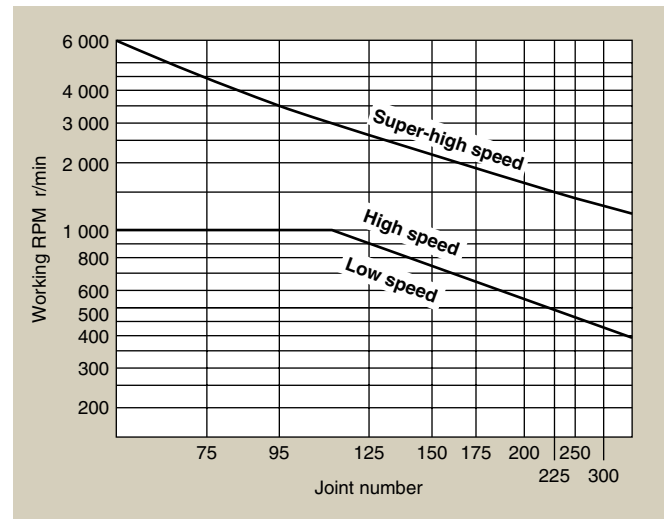

Fig. 11 Joint number versus RPM

NOTE: When selecting an optimal constant velocity joint, the location of operation and operating conditions must be considered in addition to the above-mentioned selection criteria. Contact NTN Engineering. Select a joint that satisfies all of criteria 1 through 3 above.

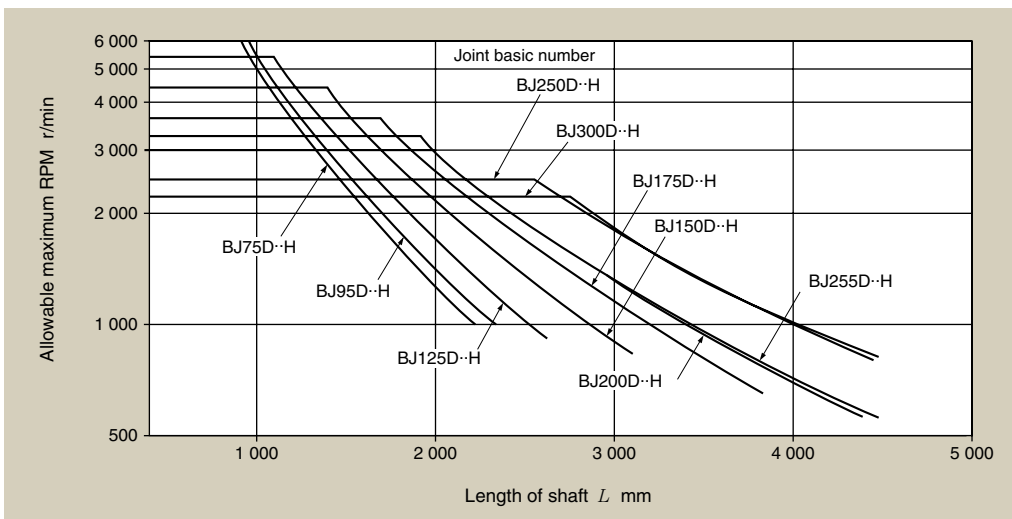

Fig. 10 Allowable RPM of shaft

Fixed Cup Type

1. When considering the durability of the boots, check that the RPM in **Fig. 12** is within the joint angle limitation.
2. Depending on the shaft length, the working number of revolutions of joint will be limited. Check the allowable RPM of the intended shaft against the data in **Fig. 13**.
3. For the allowable RPM for the CLT and CLFT series, refer to the allowable RPM data in **Fig. 14**.

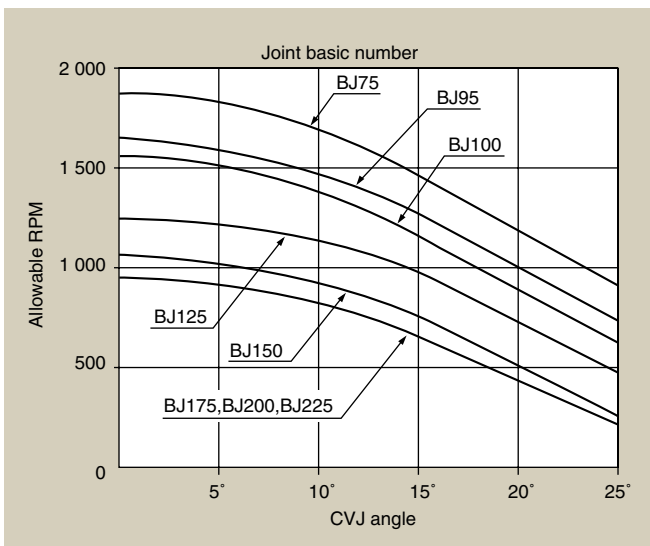

Fig. 12 Joint angle versus allowable RPM

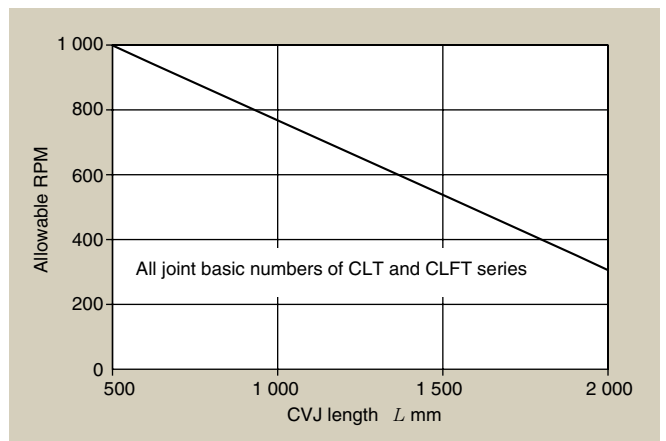

Fig. 14 Allowable RPM of shaft

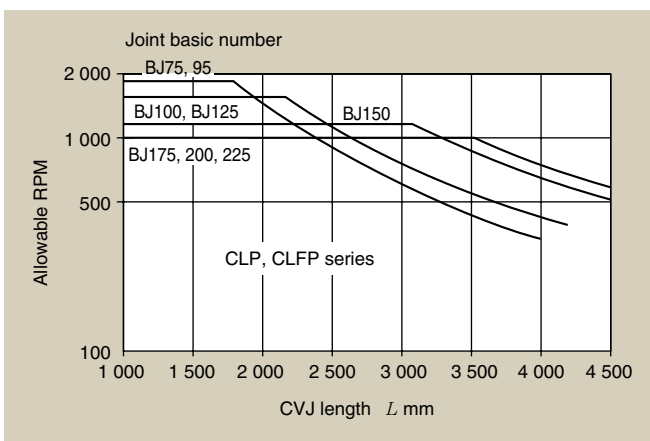

Fig.13 Allowance RPM of shaft

NOTE: When selecting an optimal constant velocity joint, the location of operation and operating conditions must be considered in addition to the above-mentioned selection criteria. Contact NTN Engineering.

Coupling Type Joint

- When considering boot durability of the boots, check that the RPM is within the joint angle limitation in **Table 3**.

Table 3 Allowable RPM of CVJ rpm

Joint basic number	Series		
	P201 P601	PB PFB	PB...H PFB...H
BC 68	3 000	1 500	3 000
BC 75	2 500	1 500	2 500
BC 87	2 000	1 500	2 000
BC 100	1 800	1 000	1 800
BC 125	1 500	1 000	1 500
BC 150	1 200	700	1 200
BC 175	1 000	700	1 000
BC 200	1 000	700	1 000

- With the long shaft series joints, depending on the shaft length, the working RPM of joint will be limited. Check the allowable RPM of the intended shaft against the data in **Fig. 15**.

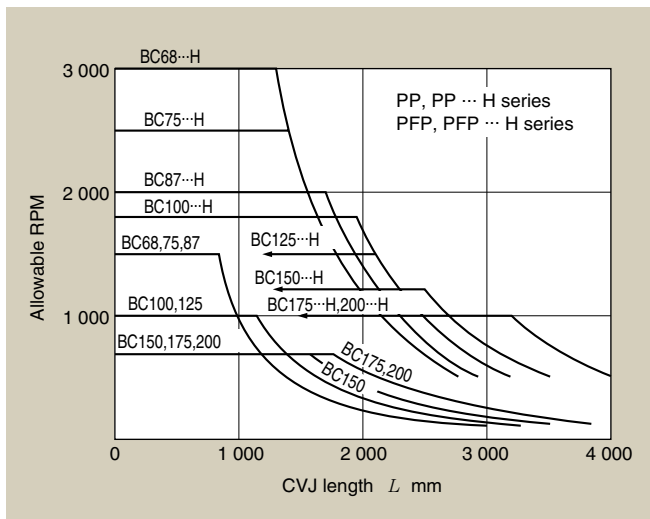

Fig. 15 Allowable RPM of CVJ

4. Large Size Series DOJ225–DOJ625

Correlation between CVJ angle and allowable expansion

When an angle occurs on a CVJ, the balls will move and the allowable expansion will decrease. The value of $2a$ in **Fig. 16** is the total expansion decrease of a pair of joints. To determine the expansion for intended application, subtract $2a$ (see **Fig. 16**) from the allowable expansion at 0°

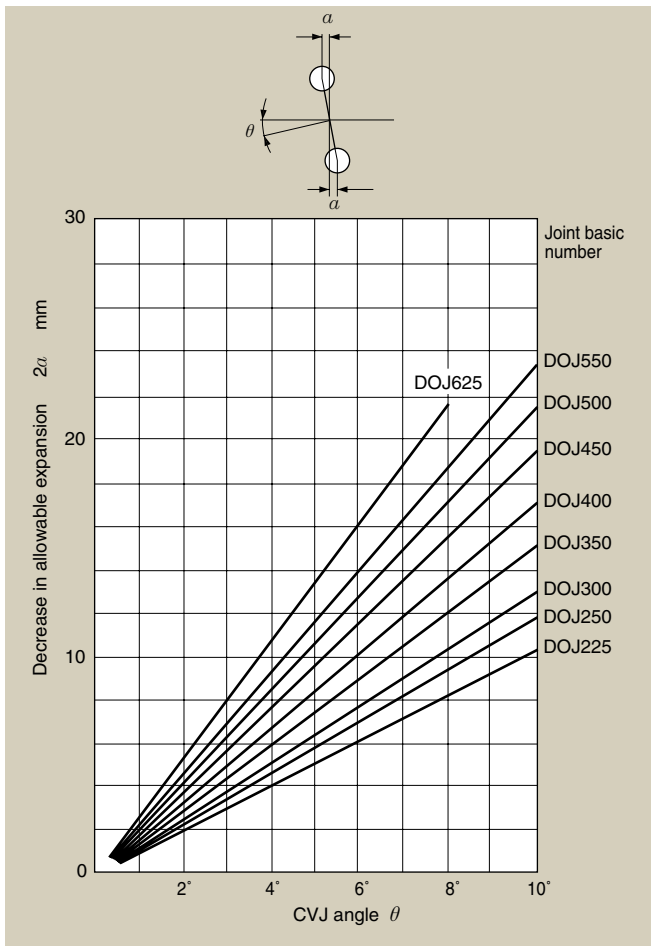

Fig. 16 Allowable expansion

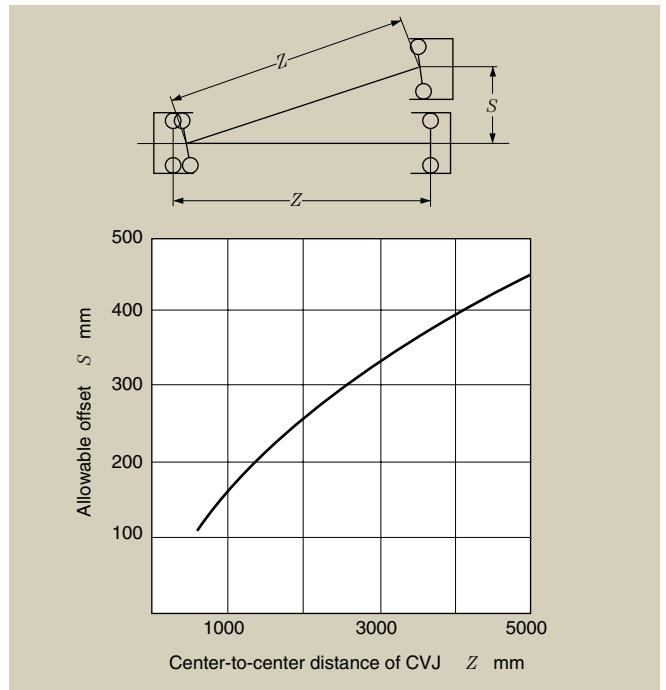

Fig. 17 Allowable offset

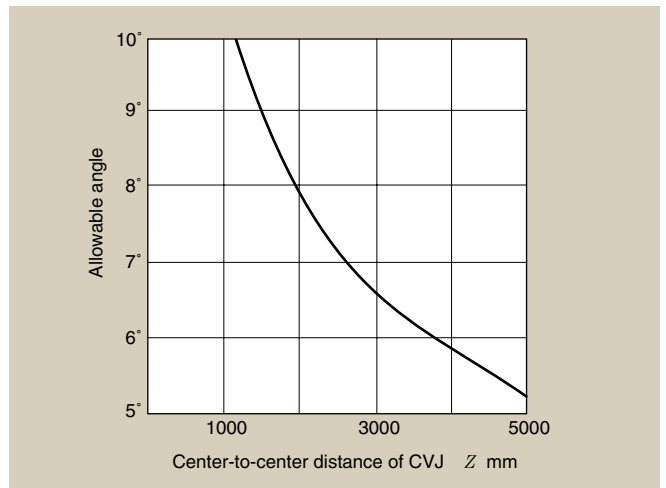

Fig. 18 Allowable angle

Remarks: The correlation between the center-to-center distance of CVJ and allowable offset is given in **Fig. 17**, and that between the center-to-center distance of CVJ and allowable angle is illustrated in **Fig. 18**.

5. Examples for Selecting a Constant Velocity Joint (Fixed Disc Type)

Example 1

Select the CVJ for a steel plate feeding pinch rollers that are used under the following conditions.

Motor output: 37 kw/1,750 RPM
 Reduction ratio: 1/3
 Normal operating output is 60% motor output.
 The peak torque when a steel plate is pinched should be taken at 150% motor output.
 Roller speed: 585 r/min
 CVJ angle during machine operation is fixed at 5°.
 This machine runs continuously 20 hours a day.

Selection

These operating conditions correspond with the load model (2) in Fig. 1 in page 12.

$$\text{Peak torque } T_{\max} = \frac{974 \times 37}{585} \times 1.5$$

$$\text{where: } 974 \text{ is conversion from KW to kgf}\cdot\text{m} \\ = 92.4 \text{ kgf}\cdot\text{m}$$

$$\text{Working torque } T_a = \frac{974 \times 37}{585} \times 0.6 \\ = 37 \text{ kgf}\cdot\text{m}$$

$$\text{From Table 1 in page 12 } K_1 = 1$$

$$\text{From Fig. 2 in page 13 } K_2 = 1.35$$

$$\text{From Fig. 3 in page 13 } K_3 = 0.90$$

Equivalent working torque

$$T_e = \frac{K_1 \times K_2}{K_3} \cdot T_a = \frac{1 \times 1.35}{0.90} \times 37 \\ = 55.5 \text{ kgf}\cdot\text{m}$$

From the equivalent working torque graphs in Fig. 8 in page 14, the joint basic number of the CVJ that satisfies 544 N·m relative to 585 RPM is **BJ125** (equivalent working torque 598 N·m). The dynamic allowable torque of this joint when torque fluctuates during revolution in one direction is 280 kgf·m, which satisfies the peak torque 92.4 kgf·m calculated above. Therefore, the CVJ **BJ125** is suited for the operating conditions above.

Example 2

Select the CVJ for driving a hydraulic pump under the following conditions.

Rated torque of drive shaft: 5kgf·m
 Speed: 1,800 RPM
 Joint angle: 4°
 This pump runs continuously 24 hours a day.

Selection

In this application, the torque remains constant. Therefore, the rated torque only should be considered.

$$\text{Operating time factor } K_2 = 1.44$$

$$\text{Operating angle factor } K_3 = 0.92$$

$$\text{Equivalent working torque } T_e = \frac{K_2}{K_3} \cdot T_a = \frac{1.44}{0.92} \times 5 \\ = 7.8 \text{ kgf}\cdot\text{m}$$

In equivalent working transmission torque graph in Fig. 8, the CVJ basic number that satisfies 7.8 kgf·m against 1,800 RPM is **BJ75** (equivalent working torque 9.6 kgf·m against 1,800 RPM).



Fixed Disc Type

Varieties of Fixed Disc Type Joints

Type	Series symbol	Structural drawing	Remarks	Page of dimensions table
Shaft assemblies	No semi-finished flange		A product consisting of two CVJs connected with a solid or hollow shaft. One joint is used for the fixed side shaft, the other for the free side shaft. Expansion during operation is provided by the splines on the free side.	P24, 25
	Complete with semi-finished flange		A product identical to DB or DP series product except having semi-finished flanges.	P26, 27
	Complete with semi-finished hub		A product identical to DB or DP series product except having semi-finished hubs.	P26, 27
CVJ with shaft head		An assembly consisting of a joint, boot, and shaft head for welding a steel pipe.	P25	
				DK (for fixed side)
Accessories	Semi-finished flange		Components for mounting the CVJ to a mating shaft.	P44, 45
	Boot		Components for containing grease within the CVJ.	P46
Hexagon headed bolt Spring washer		Components for fastening the CVJ to the mounting flanged hub.	P47	
				204 (for fixed side)
	205 (for free side)			

CVJ number

Ex. 1

A CVJ with basic number BJ75; DB series, and $L=500$

BJ75 DB 500

Joint length
Series symbol
Joint basic number

Ex. 2

A CVJ with basic number BJ125; DFP series, high speed, and $L=1,000$

BJ125 DFP 1000 H

High speed
Joint length
Series symbol
Joint basic number

Ex. 3

A CVJ with basic number BJ200; DP series, high speed, and $L=1,000$; complete with hexagon headed bolts and spring washers

BJ200 DP 1000 H Z

Standard bolts and washers
High speed
Joint length
Series symbol
Joint basic number

Fixed Disc Type (No semi-finished flange)

DB (DB...H) and DP (DP...H) series (BJ75 – 300)

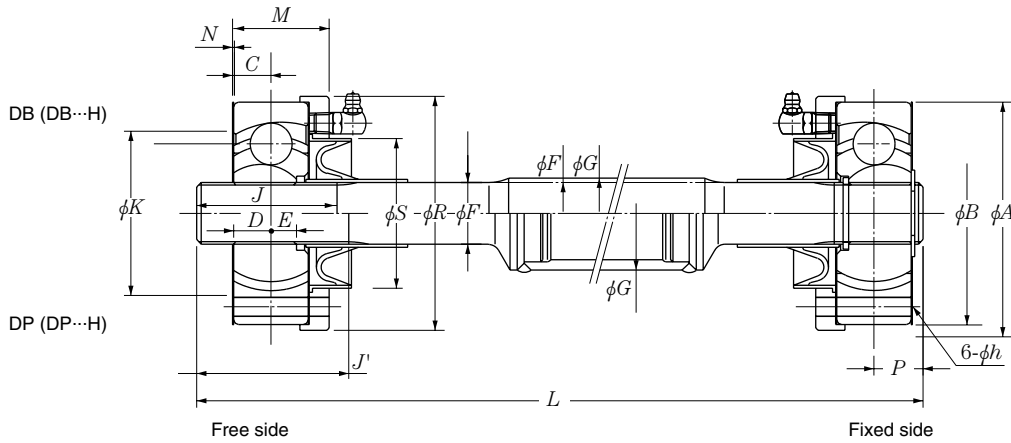

Fig. 1 BJ75 – 150

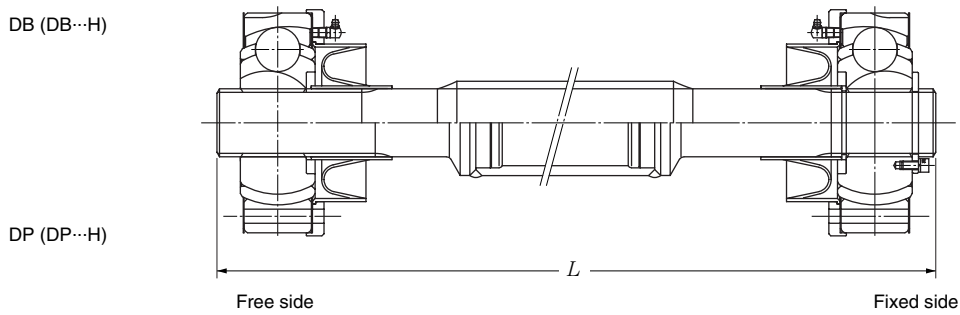

Fig. 2 BJ175 – 300

Joint basic number	Outer race		Inner race			Shaft						Circumference	Seal		Joint length L ^①					
	Outside dia. ϕA	Bolt hole		Width			DB...H ϕF	DB ϕG	DP, DP...H 48.6	Spline effective length		P	Total width N	Outside dia. ϕR	Width ϕS	N	DB	DB...H	DP	DP...H
		Pitch dia. ϕB	Hole dia. ϕh	C	D	E				J	J'						Upper line...Min. ^②	Lower line...Max.	Min. ^②	Min. ^②
BJ75	80 ⁰ _{-0.046}	66	8.5	12.2	11.0	7.9	22.33	25		50	60	16	33.9	85	51	0.5	250–	150–		510
BJ95	95 ⁰ _{-0.054}	80		15.9	14.0	10.6	26.36	30		60	70	21	41.3	100	64		280–	190–		510
BJ125	125 ⁰ _{-0.063}	106	10.5	20.3	20.3	12.1	36.33	40	60.5	75	80	29	50.1	130	82	0.5	320–	250–		610
BJ150	146 ⁰ _{-0.063}	124	12.5	24.1	21.5	17.0	45.6	50	76.3	90	90	28	57.7	151	102		340–	250–		710
BJ175	165.1 ⁰ _{-0.100}	139.7	15	25.4	28.5	18.5	51.6	55	89.1	100	120	38	62.4	170	112	0.8	380–	300–		810
BJ200	190 ⁰ _{-0.115}	159	13.5	30.0	22.5	31.5	59.5	65		120		40	72.6	196	130		400–	340–		810
BJ225	212 ⁰ _{-0.115}	180	17.5	32.5	27.6	36.0	65.4	70			130	48	77.6	218	152	0.8	440–	380–		810
BJ250	230 ⁰ _{-0.115}	197		37.5	37.5	26.5	74.25	80			145	53	87.6	238	162		460–	400–		810
BJ300	266.7 ⁰ _{-0.130}	225.4		42.0	43.0	30.0	83.4	90			150	65	97.6	273	186	0.8	500–	450–		810
																	800			

① Various joint lengths are available in increments of 5 mm within a range from a minimum to a maximum in the table.

② A joint length smaller than the minimum value is available. Contact NTN Engineering.

The maximum joint length is limited by the operating conditions, manufacturing and shipping. If a particularly long joint length is needed, contact NTN Engineering.
Remarks: The orientation of the inside construction of joint BJ200 and BJ225 differs from that in the illustrations.

Joint Assemblies with Shaft Head DS and DK Series

Fastening method: Tap bolt system DS...Free side DK...Fixed side

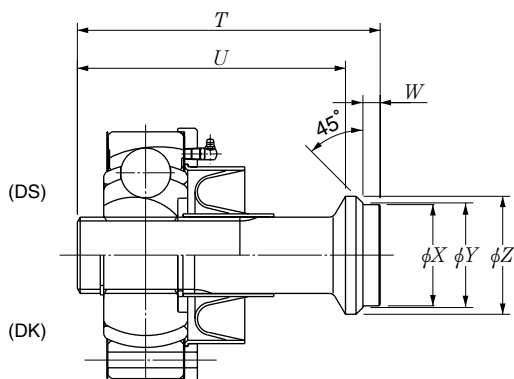

Fig. 3 BJ75 – 150

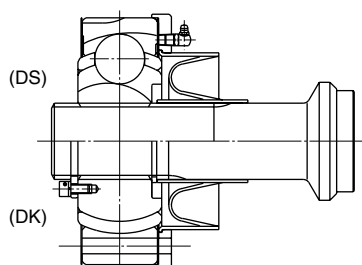

Fig. 4 BJ175 – 300

The **DS** and **DK** joint assemblies are components of **DP series**. Usually, one **DS** joint assembly and one **DK** joint assembly are welded to a segment of steel pipe before operation of the unit. The CVJ proper, shaft, boot and accessories are delivered unassembled.

Assembly sequence

1. Weld the steel pipe to the shaft heads. (See page 51.)
2. Lubricate the joint assemblies with the authorized NTN constant velocity joint grease provided.
3. Install the accessories using special tools. (See pages 59 and 60.)

Material of shaft head: **SCM440**

Recommended steel pipe material: **STKM13 or STPG 370 or equivalent**

Dimensional unit mm

Shaft head			Reference dimension	Allowable operating angle		GD ² × 10 ⁻³ kg · m ² (left column), Mass kg (right column)																
Outside dia.				Under-cut dia.	Dynamic	Static	DB				DB...H				DP, DP...H							
φX	φY	φZ	DS				DK	Length	When L=500mm	Per additional 100mm	When L=500mm	Per additional 100mm	When L=1000mm	Per additional 100mm								
41.6 ^{+0.062} ₀	42.6	48.6	135	102	8	119	86	50	14°	16°	8.67	3.77	0.12	0.39	8.55	3.54	0.08	0.31	15.8	6.87	0.96	0.49
			145	108		131	94	63			21.0	5.85	0.25	0.56	20.7	5.48	0.15	0.43	27.6	8.39		
51.7 ^{+0.074} ₀	53	60.5	190	140	10	170	120	80	16°	18°	76.3	11.7	0.79	0.99	75.7	11.3	0.54	0.81	91.0	15.6	2.1	0.75
66 ^{+0.074} ₀	67	76.3		150	163	123	96	160			17.5	1.93	1.54	159	16.9	1.33	1.28	197	23.3	5.2	1.04	
79.5 ^{+0.074} ₀	81.5	89.1	250	175	15	205	145	110	16°	18°	273	24.2	2.80	1.86	271	23.8	2.18	1.64	330	32.3	8.5	1.34
87 ^{+0.087} ₀	90	101.6				222	162	130			551	35.2	5.50	2.60	548	34.6	3.87	2.18	660	48.4	17.8	2.26
			230	172	150	904	45.9	7.40	3.02	900	45.4	5.63	2.64	1010	59.6							
123 ^{+0.100} ₀	125	139.8	320	230	20	284	194	160	18°	20°	1400	59.4	12.6	3.94	1390	58.8	9.37	3.40	1700	82.5	54	3.20
			370	260		332	222	180			2860	87.3	20.2	4.99	2850	86.9	14.9	4.29	3200	111		

Disc Type (Complete with semi-finished flange)

DFB (DFB...H) and DFP (DFP...H) series (BJ75 – 150)

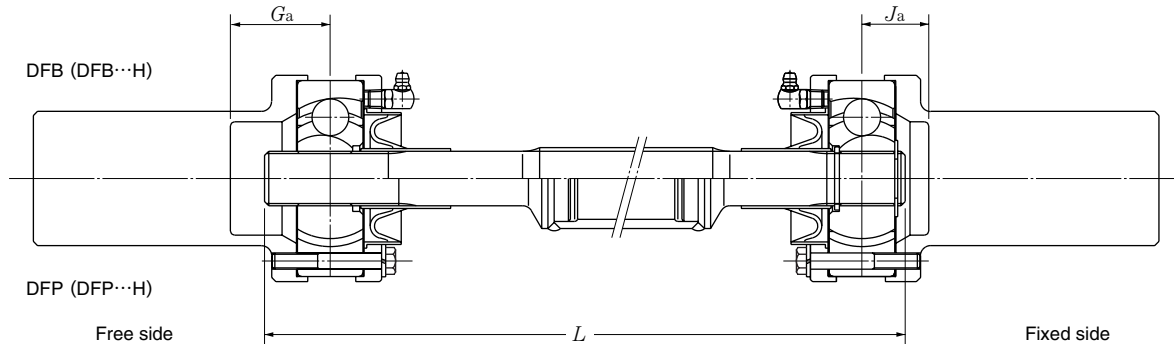

Fig. 1

DHB (DHB...H) and DHP (DHP...H) series (BJ75 – 150)

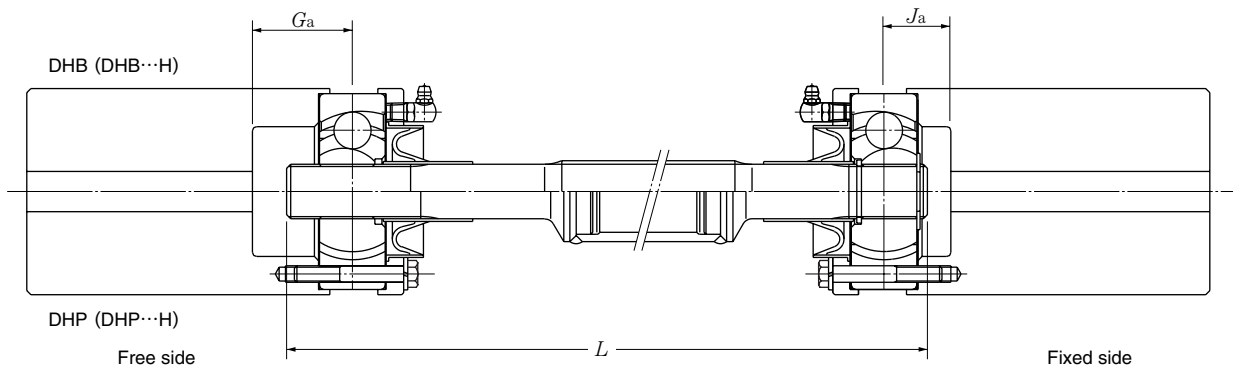

Fig. 2

Dimensional unit mm

Joint basic number	Figure	CVJ center		$GD^2 \times 10^{-3} \text{ kg} \cdot \text{m}^2$ (left column), Mass kg (right column)											
		G_a	J_a	Upper line... DFB Lower line... DHB		Upper line... DFB...H Lower line... DHB...H		Upper line... DFP, DFP...H Lower line... DHP, DHP...H							
				When $L=500\text{mm}$	Per additional 100mm	When $L=500\text{mm}$	Per additional 100mm	When $L=1000\text{mm}$	Per additional 100mm	When $L=1000\text{mm}$	Per additional 100mm				
BJ75	1	36.7	24.7	16.4	7.15	0.12	0.39	16.3	6.92	0.08	0.31	23.6	10.3	0.96	0.49
	2			45.3	13.6			45.2	13.3			52.4	16.7		
BJ95	1	48.4	32.4	40	12.5	0.25	0.56	39.8	12.1	0.15	0.43	46.6	15.0	0.96	0.49
	2			106	22.2			106	21.8			113	24.7		
BJ125	1	60.8	40.8	152	26.1	0.79	0.99	151	25.7	0.54	0.81	166	30.0	2.1	0.75
	2			362	40.7			362	40.3			375	44.6		
BJ150	1	72.6	48.6	323	40.2	1.93	1.54	322	39.6	1.33	1.28	360	46.0	5.2	1.04
	2			749	60.7			748	60.1			782	66.5		

DFB (DFB...H) and DFP (DFP...H) series (BJ175 – 300)

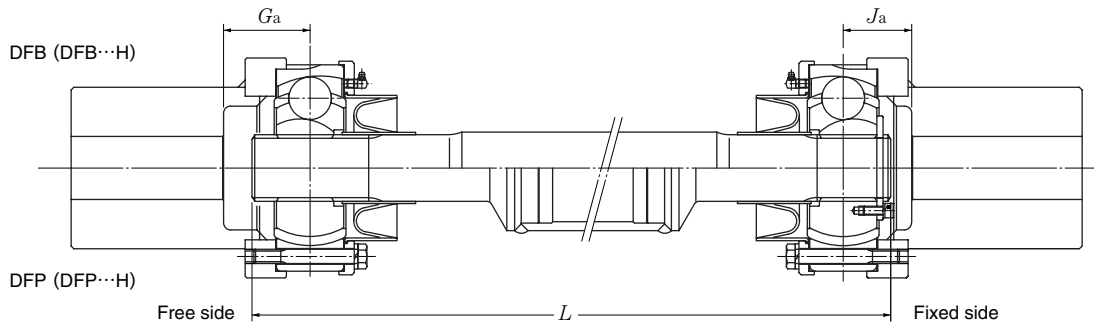

Fig. 3





Dimensional unit mm

Joint basic number	CVJ center		$GD^2 \times 10^{-3} \text{ kg} \cdot \text{m}^2$ (left column), Mass kg (right column)											
	G_a	J_a	DFB				DFB...H				DFP, DFP...H			
			When $L=500\text{mm}$		Per additional 100mm		When $L=500\text{mm}$		Per additional 100mm		When $L=1000\text{mm}$		Per additional 100mm	
BJ175	80.2	60.2	596	53.9	2.80	1.86	594	53.5	2.18	1.64	653	62.0	8.5	1.34
BJ200	85.8	65.8	1180	77.1	5.50	2.60	1180	76.5	3.87	2.18	1290	90.3	17.8	2.26
BJ225	88.3	68.3	1960	105	7.40	3.02	1960	104	5.63	2.64	2070	118		
BJ250	96.3	76.3	3250	140	12.6	3.94	3240	139	9.37	3.40	3550	163	54.0	3.20
BJ300	112.8	87.8	6200	200	20.2	4.99	6190	199	14.9	4.29	6540	223		

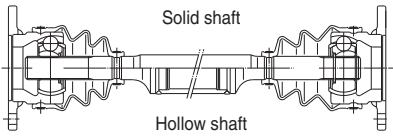
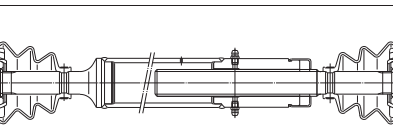
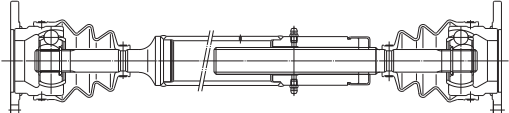
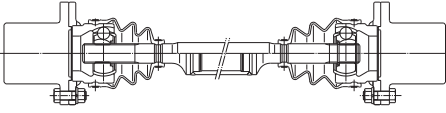

Fixed Cup Type

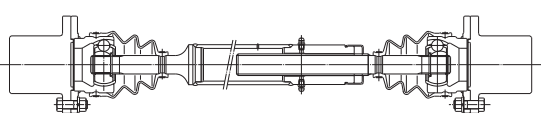
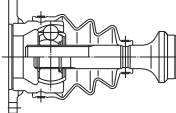
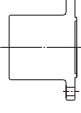
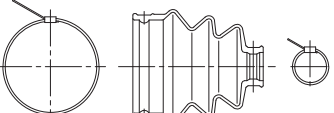
Varieties of Fixed Disc Type Joints

Type	Series symbol	Structural drawing	Remarks	Page of dimensions table
Shaft assemblies	No semi-finished flange	CLB 	A product consisting of two CVJs connected with a solid or hollow shaft. One joint is used for the fixed side shaft, the other for the free side shaft. Expansion during operation is provided by the splines on the free side.	P30, 31
		CLP 		
		CLT 		
	Complete with semi-finished flange	CLFB 	A product identical to CLB or CLP series product except having semi-finished flanges.	P32
		CLFP 		
		CLFT 		
Joint assemblies	CVJ with shaft head	CLS (for free side) 	An assembly consisting of a CVJ, boot, and shaft head for welding a steel pipe.	P31
		CLK (for fixed)		
Accessories	Semi-finished flange	400 800 	A component for mounting the CVJ to a mating shaft.	P44, 45
	Boot Boot band	— 	Components for containing grease within the CVJ.	P46
	Hexagon headed bolt Spring washer Hexagon nut	— 	Components for fastening the CVJ to the mounting flanged hub.	P47

CVJ number

Ex. 1
A CVJ with basic number BJ75;
CLB series, and $L=500$

BJ75 CLB 500

Joint length
Series symbol
Joint basic number

Ex. 2
A joint with basic number BJ125;
CLFT series, and $L=1,000$

BJ125 CLFT 1000

Joint length
Series symbol
Joint basic number

Cup Type (No semi-finished flange)

CLB and CLP series (BJ75 – 225)

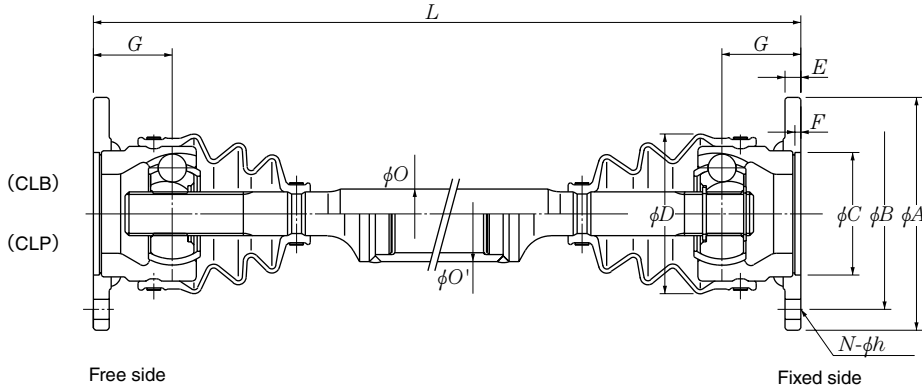

CLT series (BJ75 – 225)

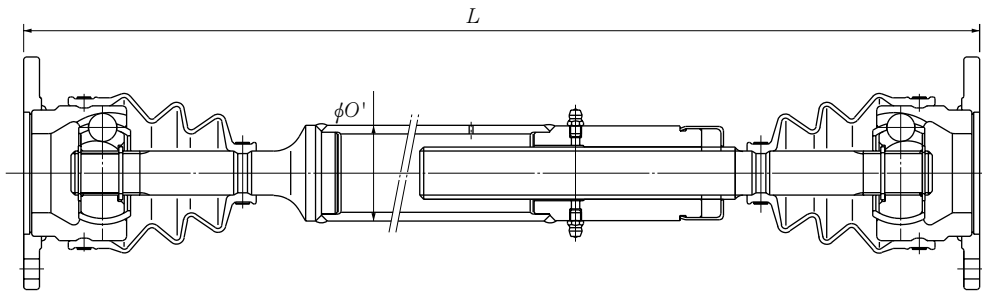

Dimensional data Joint basic number	Outer race						Boot Outside dia. ϕD (approx.)	Shaft		CVJ center G	Joint length L ①			
	Outside dia. ϕA	Bolt hole Pitch dia. ϕB	Hole dia. $N-\phi h$	Socket dia. ϕC	Width E F			CLB ϕO (Max.)	CLP, CLT $\phi O'$		CLB	CLP Min. – Max.	CLT	
BJ75	118	97	3-10.2	62	$+0.074$ 0	8	3	81	25	48.6	40	240–540	550–4000	460–2000
BJ95	136	110	3-12.2	70	$+0.074$ 0	10		108	30		46	290–540	550–4000	520–2000
BJ100	154	125	3-14.3	80	$+0.074$ 0		3.5	112	32	60.5	47	305–540	550–4200	580–2000
BJ125	179	150		102	$+0.087$ 0	148		40	55		380–650	660–4200	610–2000	
BJ150	192	165	6-14.3	110	$+0.087$ 0	12	165	50	89.1	76	480–780	790–4500	830–2000	
BJ175	215	185	6-17	125	$+0.100$ 0	15	5	172	55	101.6	83	470–880	890–4500	910–2000
BJ200	250	215	6-19	140	$+0.100$ 0	16		199	65		95	540–900	910–4500	950–2000
BJ225	265	228	6-21	155	$+0.100$ 0	18	222	70	139.8	105	580–900	1050–2000		

① Various joint lengths L are available in increments of 5 mm within a range from a minimum to a maximum.

② The allowable expansion data is based on the center-to-center distance d relative to the operating angle indicated.

Remarks: The form of boot can differ from that in the illustration depending on the joint basic number.

Joint with Shaft Head CLS and CLK Series (BJ75 – 225)

Fastening method: Through bolt system CLS...Free side CLK...Fixed side

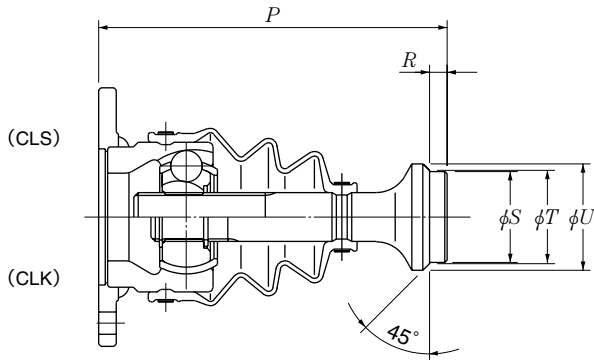

The **CLS** and **CLK** joint assemblies are components of the **CLP** series. Usually one **CLS** and one **CLK** joint assembly is welded to a segment of steel pipe before operation of the shaft assembly. The CVJ assemblies, shaft heads, grease and boots are delivered unassembled.

Assembly sequence

1. Weld the steel pipe to the shaft heads. (See page 51.)
2. Lubricate the joints with the provided grease for NTN constant velocity joints.
3. Install the accessories. (See pages 59 and 60.)

Material of shaft head: SCM440

Recommended steel pipe material: STKM13 or STPG 370 or equivalent

Dimensional unit mm

Shaft head					Allowable expansion ^②			Allowable operating angle		GD ² × 10 ⁻³ kg · m ² (left column), Mass kg (right column)											
Outside dia. (approx.)			Length		15° or less	15° or more, and 25° or less	CLT	Dynamic	Static	CLB		CLP		CLT							
ϕS	ϕT	ϕU	CLS	CLK						When L=500mm	Per additional 100mm	When L=1000mm	Per additional 100mm	When L=1000mm	Per additional 100mm						
41.6 ^{+0.062} ₀	42.6	48.6	151	159	±10	+10 -5	+80 -6			14.8	4.17	0.12	0.39	21.9	7.52	0.96	0.49	22.3	8.35	0.96	0.49
			165	170						32.6	6.42	0.25	0.56	39.4	9.44			40.5	10.6		
51.7 ^{+0.074} ₀	53	60.5	210	215	±10		+90 -8	25°	38°	51.5	8.12	0.32	0.63	65.2	13.2	2.1	0.75	67.1	14.5	2.1	0.75
			214	216						109	12.5	0.79	0.99	122	17.2			124	18.6		
79.5 ^{+0.074} ₀	81.5	89.1	299	306	±15		+120 -15			263	21.3	1.93	1.54	314	31.1	8.5	1.34	329	36.7	8.5	1.34
			305	315						469	29.2	2.80	1.86	567	44.1			590	52.8		
87 ^{+0.087} ₀	90	101.6	337	343			+150 -15			964	45.4	5.50	2.60	1053	60.1			1081	69.0		
			123 ^{+0.100} ₀	125						138.9	364	371	30	1450	58.3			7.40	3.02		

Cup Type (Complete with semi-finished flange)

CLFB and CLFPseries (BJ75 – 225)

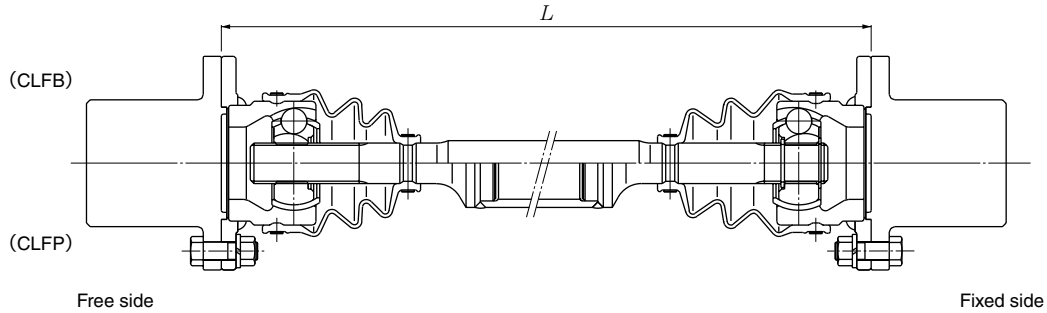

CLFTseries (BJ75 – 225)

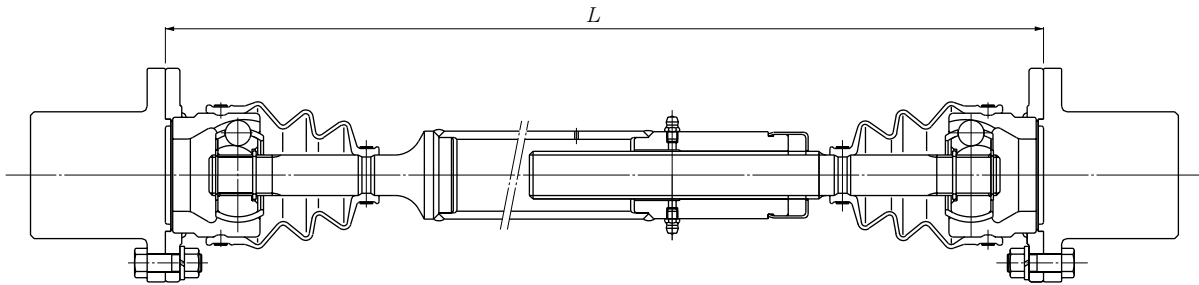

Dimensional data Joint basic number	$GD^2 \times 10^{-3} \text{ kg} \cdot \text{m}^2$ (left column), Mass kg (right column)											
	CLFB				CLFP				CLFP			
	When $L=500\text{mm}$		Per additional 100mm		When $L=1000\text{mm}$		Per additional 100mm		When $L=1000\text{mm}$		Per additional 100mm	
BJ75	38.0	10.0	0.08	0.39	45.1	13.2	0.96	0.49	45.5	14.2	0.96	0.49
BJ95	79.0	14.9	0.15	0.56	85.8	17.6			86.9	19.3		
BJ100	143	20.9	0.24	0.63	157	25.6	2.1	0.75	159	27.1	2.1	0.75
BJ125	303	33.5	0.54	0.99	316	37.8			318	39.4		
BJ150	552	46.2	1.93	1.54	603	56.2	8.5	1.34	618	61.2	8.5	1.34
BJ175	1011	66.0	2.80	1.86	1110	80.0	17.8	2.26	1133	88.9	17.8	2.26
BJ200	2004	98.1	5.50	2.60	2093	112			2121	121		
BJ225	3026	128	7.40	3.02	3254	151	54.0	3.20	3414	171	54.0	3.20

Sliding Type

Varieties of Sliding Type Joint

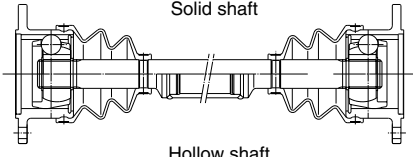
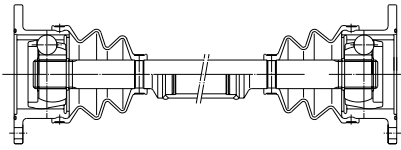
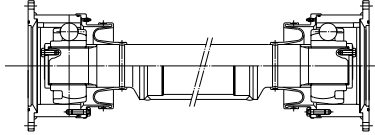
Type	Series symbol	Structural drawing	Remarks	Page of dimensions table
Shaft assemblies	Small	DOJ68-100 	Two compact flange type CVJs proper are connected with a solid or hollow shaft. Expansion during operation is achieved within the CVJs proper. This series is non-standard.	P34, 35
		DOJ125-200 		
	Large	FSB FSP	DOJ225-625 	Two large flange type CVJs proper are connected with a solid or hollow shaft. Expansion during operation is achieved within the CVJs proper.

CVJ number

Ex. 1 A CVJ with basic number DOJ225;
FSB series, and $L=1,000$

DOJ225 FSB 1000

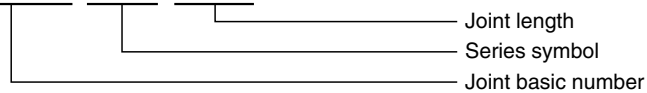

Ex. 2 A joint with basic number DOJ225;
FSP series, and $L=2,000$

DOJ225 FSP 2000

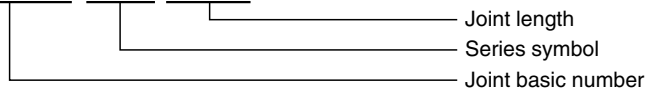

Sliding Type

F Series (reference)

The allowable operating range of a sliding type joint is governed by interrelation among the RPM, operating angle and expansion. When considering use of this type, contact NTN Engineering.

DOJ68 – 100

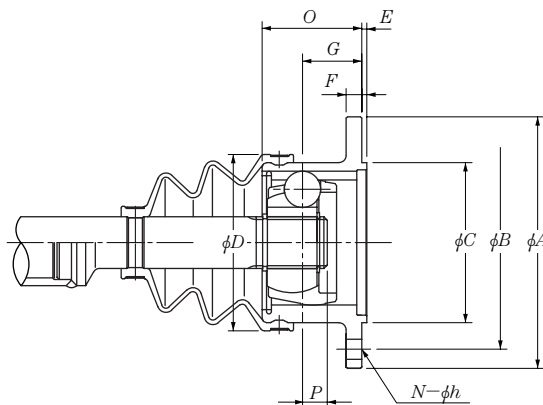

DOJ125 – 200

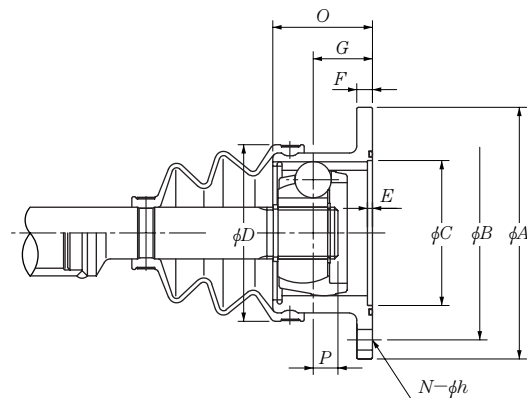

Dimensional unit mm

Dimensional data Joint basic number	Outer race			Socket ϕC	Width E	Width F	Width O ①	Boot Outside dia. (approx.) ϕD	Shaft Length P	Joint length G ②	Allowable expansion ③		Allowable operating angle
	Outside dia. ϕA	Bolt hole Pitch dia. ϕB	Hole dia. $N-\phi h$								At 0°	At 20°	
DOJ68	95	76	3-10.5	60 0 -0.074	1.5	6	44	70	9.5	19	±10	±6	20°
DOJ75	106	87	3-10.2	70 0 -0.074	3	8	50	78	11	28.5	±13	±8	
DOJ87	125	105		78 0 -0.074									
DOJ100	146	122	3-14.2	91 0 -0.087	3.5	11	65	100	15	40	±12	±5	
DOJ125	177	150	3-14.3	102 +0.087 0									
DOJ150	215	185	3-16.4	124 +0.100 0	4	13	85	154	21	51	±15	±6	
DOJ175	236	203	4-18.4	140 +0.100 0	5	15	90	175	25	60	±18	±7	
DOJ200	270	233	4-20.4	165 +0.100 0									

①, ② and ③ are reference values.

The sliding CVJ can be used in two forms: a combination of two sliding CVJs connected with an intermediate shaft, and a configuration comprised of one sliding CVJ and a fixed CVJ to the other end.

[Ex. 1] Example combination of [sliding CVJ] + [sliding CVJ]

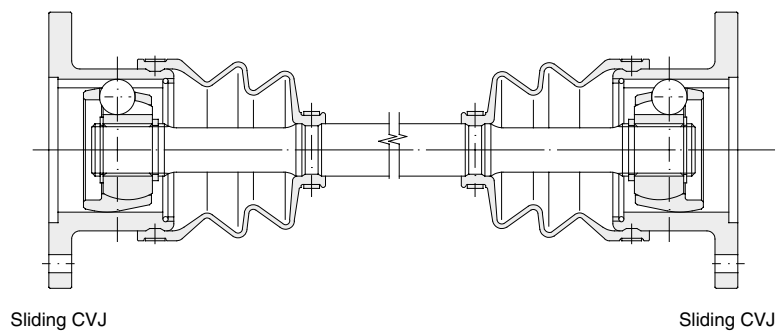

[Ex. 2] The example shows a combination of [sliding CVJ] + [fixed cup CVJ]

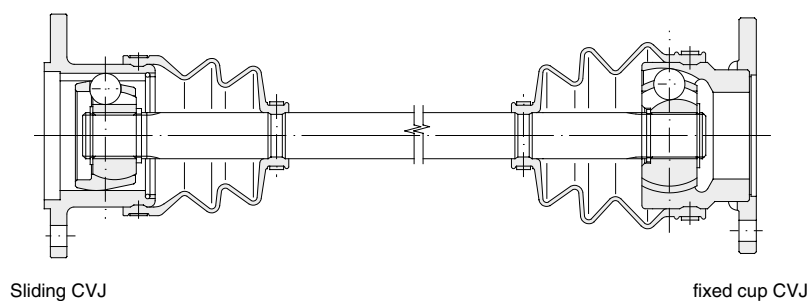

Sliding Type

FSB and FSP series (DOJ225 – 625)

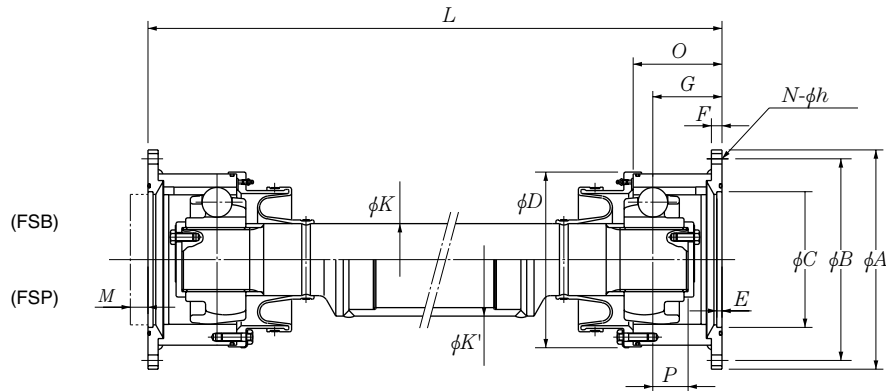

Dimensional data Joint basic number	Outer race									Shaft			Joint length ^①		
	Outside dia.		Bolt hole ^②		Socket		Width			Outside dia.		Length P	FSB L Min. – Max.	FSP L Min.	G
	ϕA	ϕD	Pitch dia. ϕB	Hole dia. $N-\phi h$	ϕC	E	F	O	FSB ϕK	FSP $\phi K'$					
DOJ225	244	180	222	8-12.2	140 $+0.063$ 0	5	11	131	73	101.6	36	430–1200	550	106	
DOJ250	272	205	248	8-14.2	160 $+0.063$ 0	6	13	133	82	139.8	41	450–1200	590	108.5	
DOJ300	292	226	268		180 $+0.063$ 0			143	98						45
DOJ350	336	260	308	8-16.2	210 $+0.072$ 0	8	15	150	108	165.2	54.5	540–1200	740	119.5	
DOJ400	376	296	344	8-18.2	240 $+0.072$ 0			18	163	126	190.7	57.5	570–1200	810	127.5
DOJ450	420	335	386	8-20.2	260 $+0.081$ 0	10	20	170	138	216.3	67.5	650–1200	900	132.5	
DOJ500	462	370	424	8-22.5	290 $+0.081$ 0			22	177	155	267.4	76	720–1200	1000	133.5
DOJ550	504	407	464	8-24.5	320 $+0.089$ 0			25	185	170		81	770–1200	1070	139.5
DOJ625	580	445	520	8-30.5	360 $+0.089$ 0	12	34	229	200	280	95	840–1200	1170	185	

① Various joint lengths L are available in increments of 5 mm within a range from a minimum to a maximum in the table.

② Upon request from the user, the bolt holes may be finished with a reamer. Contact NTN Engineering.

Dimensional unit mm

Under-cut on flange <i>M</i>	Allowable expansion At 0°	Allowable number of revolutions rpm	Allowable operating angle	GD ² × 10 ⁻³ kg · m ² (left column), Mass kg (right column)							
				FSB series				FSP series			
				When L=1000mm		Per additional 100mm		When L=2000mm		Per additional 100mm	
22	±35	2200	10°	0.907	62.4	0.0087	3.28	1.11	83.7	0.0163	2.26
28		2000		1.58	83.2	0.0139	4.14	1.99	123	0.0275	3.20
	±38	1800		2.43	110	0.0284	5.92	3.07	148	0.0499	
34	±40	1600		4.58	147	0.0419	7.19	5.67	199	0.0848	3.83
		1300		8.41	205	0.0776	9.78	10.6	273	0.169	5.29
36	±44	1200		14.6	272	0.112	11.7	18.4	385	0.287	7.45
46	±46	1100		23.6	350	0.178	14.8	30.8	543	0.494	11.1
48	±50	1000		36.3	450	0.257	17.8	44.3	645	0.629	
52		800		8°	63.9	606	0.493	24.66	75.4	869	0.872



Coupling Type

Varieties of Coupling Type Joint

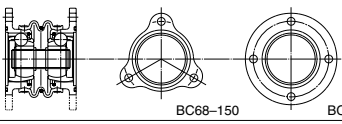
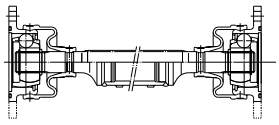
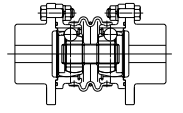
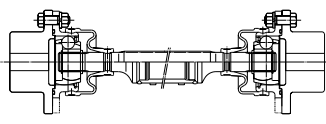
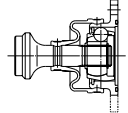
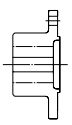
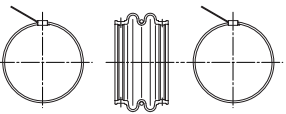
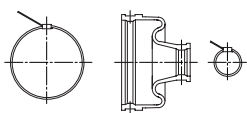
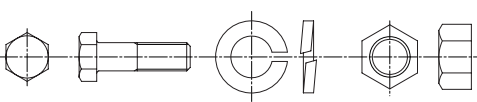
Type		Series symbol	Structural drawing	Remarks	Page of dimensions table
Shaft assemblies	No semi-finished flange	Short shaft	P201 	A compact CVJ assembly consisting of two sliding flanged type CVJs connected with a solid shaft. Expansion during operation occurs within the joints.	P40, 41
		Long shaft	PB PB··H PP PP··H 	Two sliding flange type CVJs proper are connected with a solid shaft or hollow shaft to constitute a compact product. Expansion during operation is achieved within the CVJs proper.	
	Complete with semi-finished flange	Short shaft	P601 	A product identical to P201 series product except having semi-finished hubs.	P42, 43
		Long shaft	PFB PFB··H PFP PFP··H 	A product identical to PB or PP series product except having semi-finished flanges.	
Joint assemblies	CVJ with shaft head	PK 	An assembly consisting of a CVJ, boot, and shaft head for welding a steel pipe.	P41	
Accessories	Semi-finished flange	150 	Components for mounting the CVJ to a mating shaft.	P44, 45	
	Boot Boot band	—	for long shaft 	Components for containing grease within the CVJ.	P46
		—	for short shaft 		
Small hexagon nut Spring washer Small hexagon headed bolt	—		Components for fastening the CVJ to the mounting flanged hub.	P47	

CVJ number

Ex. 1
A CVJ with basic number BC68;
P201 series

BC68AC P201

Series symbol
Joint basic number

Ex. 2
A CVJ with basic number BC68;
P201 series, complete with accessories
(bolts, nuts and washers)

BC68AC P2100

Series symbol
Joint basic number

Ex. 3
A CVJ with basic number BC68;
PFP series, high speed, and $L=1,000$

BC68 PFP 1000 H

High speed
Joint length
Series symbol
Joint basic number

Coupling Type (No semi-finished flange)

PB (PB...H) and PP (PP...H) series (BC68 – 200)

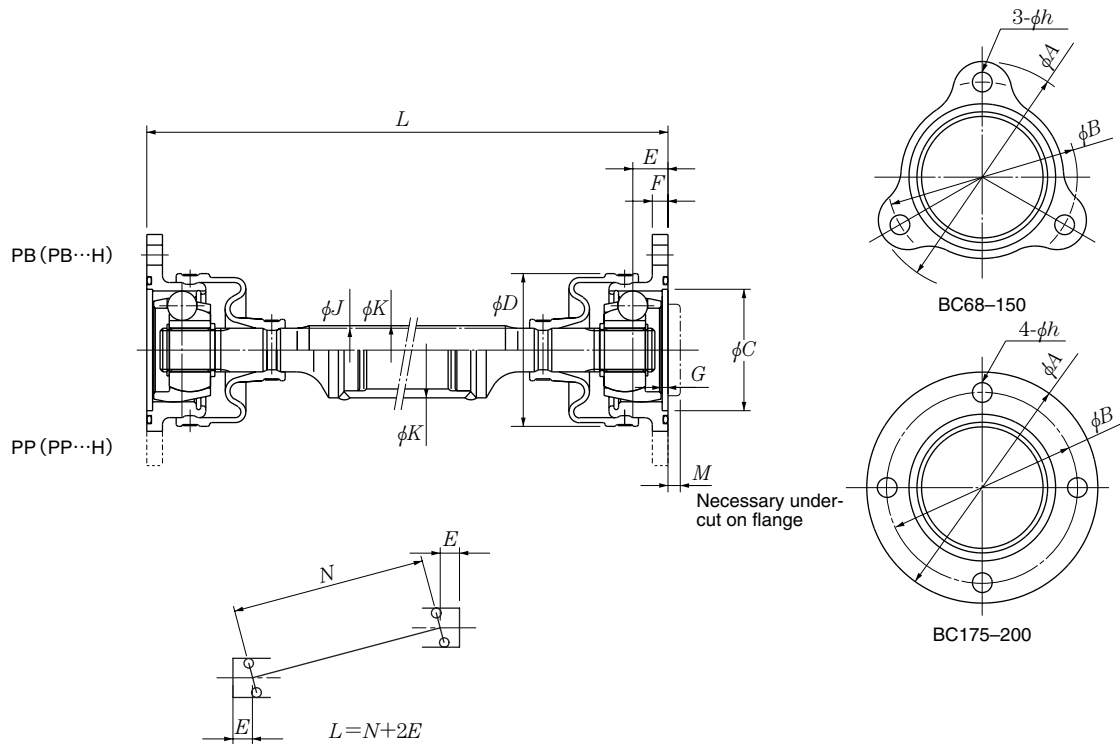

Joint basic number	Outer race			Socket dia. ϕC	Width		Boot Outside dia. ϕD (approx.)	Shaft			CVJ center E	Joint length ^①				Necessary under-cut M	Allowable offset O
	Outside dia. ϕA	Bolt hole Pitch dia. ϕB	Hole dia. ϕh		F	G		PB...H ϕJ	PB ϕK	PP PP...H		PB Upper line...Min. Lower line...Max.	PB...H PP, PP...H Min.-Max.	L'	Allowable range of $L(L')$, when installed		
BC68	105	86	8.2	55 $^{+0.074}_0$	7	2.5	72	22			16	185-610	130-2800	72	$^{+4}_0$	3	3.5
BC75	118	97	10.2	62 $^{+0.074}_0$	8		78	22.3	25		18	205-660	145-2800	82			4
BC87	134	110	12.2	70 $^{+0.074}_0$	10	3	90	26.3	30		20	215-715	155-3000	94		4.5	5
BC100	152	125	14.3	80 $^{+0.074}_0$	11	3.5	100	29.5	32	60.5	23	250-770	195-3200	108	$^{+8}_0$		
BC125	177	150		102 $^{+0.087}_0$			124	36.3	40	28	305-815	235-3200	130		7	7	
BC150	215	185	16.4	124 $^{+0.100}_0$	13	4	154	45.6	50	76.3	35	335-825	275-3500	156		6.5	8
BC175	236	203	18.4	140 $^{+0.100}_0$	15	5	175	51.6	55	89.1	38	380-825	315-4000	180	$^{+10}_0$	8	9
BC200	270	233	20.4	165 $^{+0.100}_0$		6	200	59.5	65	101.6	45	430-835	360-4000	216		7	11.5

① Various joint lengths are available in increments of 5 mm within a range from a minimum to a maximum in the table.

Remarks: A joint provided with standard bolts, nuts and spring washers is identified with Z at the end of its part designation.

(Ex.) BC68PB315Z

P201 series (BC68AC – 200AC)

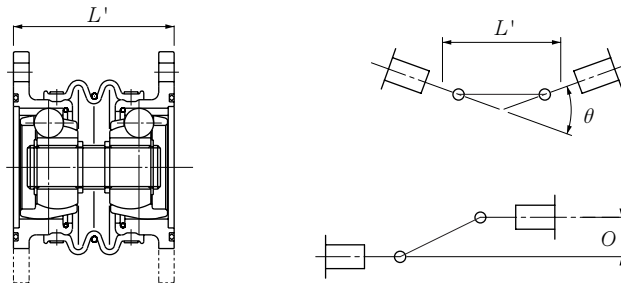

Joint Assemblies with Shaft Head PK Series PK series (BC68 – 200)

The **PK** joints are components of **DP** series joint assemblies. One **PK** joint assembly are welded to a segment of steel pipe before operation of the unit. Two disc type CVJ assemblies, shaft heads, boots, grease, and associated accessories are delivered unassembled.

Assembly sequence

1. Weld the steel pipe to the shaft heads. (See **page 51**.)
2. Lubricate the joint assemblies with the authorized NTN constant velocity joint grease provided.
3. Install the accessories. (See **pages 59 and 60**.)

Material of shaft head: SCM440

Recommended steel pipe material: STKM13 or STPG 370 or equivalent

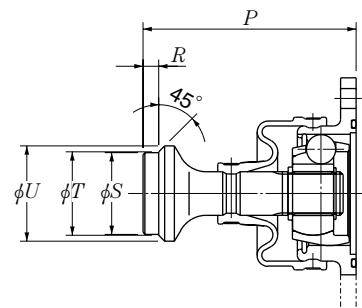

Dimensional unit mm

Shaft head						GD ² × 10 ⁻³ kg · m ² (left column), Mass kg (right column)															
Outside dia.			Standard dimension Length		Tolerance of P, when installed to the machine	Allowable operating angle θ	PB				PB···H				PP, PP···H		P201				
φS	φT	φU	P	R			When L=500mm	Per additional 100mm	When L=500mm	Per additional 100mm	When L=500mm	Per additional 100mm	When L=500mm	Per additional 100mm							
41.6	^{+0.062} ₀	42.6	48.6	92.5	8	+2 0	5°	4.48	2.79	0.12	0.39	4.29	2.44	0.07	0.30	7.38	3.55	3.85	1.4		
				6.28				3.39	6.14			3.11	0.08	0.31	9.03	4.19					
				115				13.3	4.92	0.25	0.56	12.9	4.49	0.15	0.43	15.6	5.13				
51.7	^{+0.074} ₀	53	60.5	128	10	+4 0	5°	23.2	6.15	0.32	0.63	22.9	5.87	0.22	0.54	29.1	7.18	2.1	0.75	21.8	4.4
				57.4				10.4	0.79	0.99	56.7	9.58	0.54	0.81	62.0	10.7	54.3			7.3	
				150.5				148	17.5	1.93	1.54	147	16.9	1.33	1.28	161	18.6	5.2	1.04	140	13.4
79.5	^{+0.074} ₀	81.5	89.1	208	15	+5 0	5°	371	28.0	2.80	1.87	370	27.5	2.18	1.64	387	30.6	8.5	1.34	361	24.5
				227				585	43.9	5.50	2.60	582	43.2	3.87	2.18	613	47.6	17.8	2.26	571	36.2

Coupling Type (Complete with semi-finished flange)

PFB (PFB...H) and PFP (PFP...H) series (BC68 – 200)

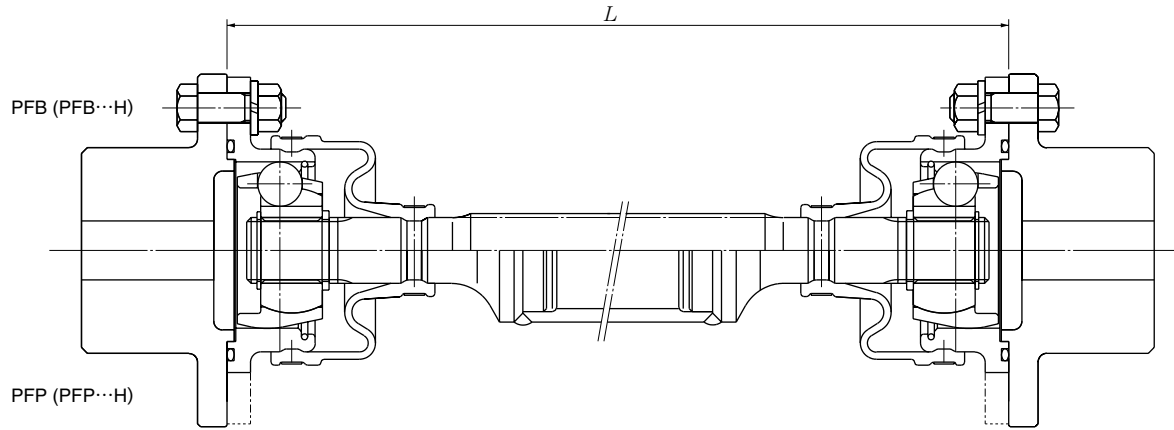

Dimensional unit mm

Dimensional data Joint basic number	GD ² × 10 ⁻³ kg · m ² (left column), Mass kg (right column)											
	PFB				PFB...H				PFP, PFP...H			
	When L=500mm		Per additional 100mm		When L=500mm		Per additional 100mm		When L=500mm		Per additional 100mm	
BC68	14.2	5.25	0.12	0.39	14.0	4.90	0.07	0.30	17.0	6.01	0.96	0.49
BC75	26.7	7.47			26.6	7.19	0.08	0.31	29.5	8.27		
BC87	52.9	11.1			52.5	10.4	0.15	0.43	55.2	11.1		
BC100	102	14.8	0.32	0.63	102	14.5	0.22	0.54	108	15.8	2.1	0.75
BC125	227	24.2	0.79	0.99	226	23.4	0.54	0.81	232	24.5		
BC150	563	41.8	1.93	1.54	562	41.2	1.33	1.28	576	42.9		
BC175	1128	64.4	2.80	1.87	1127	63.9	2.18	1.64	1130	67.0	8.5	1.34
BC200	2041	101	5.50	2.60	2038	100	3.87	2.18	2068	105	17.8	2.26

P601 series (BC68AC–200AC)

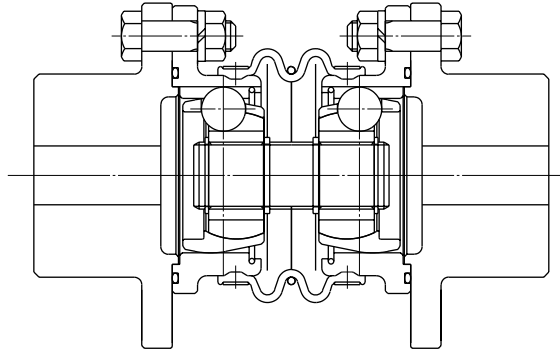

Dimensional data Joint basic number	P601	
	$GD^2 \times 10^{-3} \text{ kg} \cdot \text{m}^2$	Mass kg
BC68	14.1	3.9
BC75	26.0	5.9
BC87	51.5	8.5
BC100	99.7	13.1
BC125	223	21.2
BC150	553	37.8
BC175	1118	62.8
BC200	2025	95

Accessories

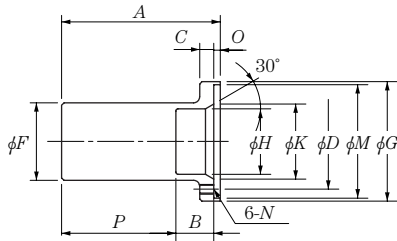

Fig. 1
Disc (BJ75-150)
201, 202 series

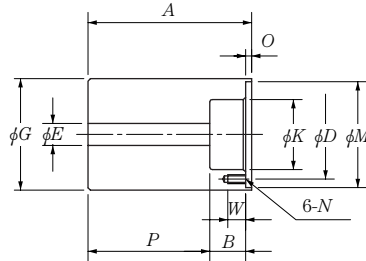

Fig. 2
Disc (BJ75-150)
204, 205 series

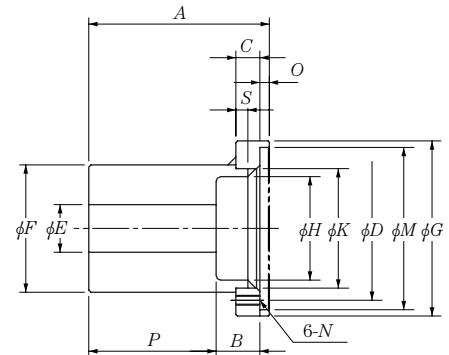

Fig. 3
Disc (BJ75-300)
201, 202 series

Applicable joint	Type	Figure	Parts number	Width				Outside dia.		Socket			
				A	B	C	P	φF	φG	φM	O		
BC68	Coupling type	5	50-150#BC68	40	5	9	35	60	107	55 ⁰ _{-0.046}	2		
BJ75	Disc type	1	Fixed side	50-201#BJ75	91	12	12	74	55	85	80 ^{+0.046} ₀	5	
			Free side	50-202#BJ75									24
		2	Fixed side	50-204#BJ75	121	12	—	104	—	—	—	—	—
			Free side	50-205#BJ75									
	Cup type	4	50-400#BJ75	77	2.5	10	74.5	70	118	62 ⁰ _{-0.046}	2.5		
BC75	Coupling type	5	50-150#BC75	52	7	12	45	70	120	70 ⁰ _{-0.046}	2.5		
BC87			50-150#BC87	57			50	80	136				
BJ95	Disc type	1	Fixed side	50-201#BJ95	133	16	112	65	100	95 ^{+0.054} ₀	5		
			Free side	50-202#BJ95								32	96
		2	Fixed side	50-204#BJ95	147	16	—	126	—	—	—	—	
			Free side	50-205#BJ95									32
BJ100	Cup type	4	50-400#BJ100	97	2.5	15	94.5	90	136	70 ⁰ _{-0.046}	2.5		
BC100	Coupling type	5	50-150#BC100	67	7	15	60	90	154	80 ⁰ _{-0.046}	2.5		
BJ125	Disc type	1	Fixed side	50-201#BJ125	155	20	130	110	130	125 ^{+0.063} ₀	5		
			Free side	50-202#BJ125								40	110
		2	Fixed side	50-204#BJ125	175	20	—	150	—	—	—	—	
			Free side	50-205#BJ125									40
	Cup type	4	50-400#BJ125	115	3	15	112	110	179	102 ⁰ _{-0.054}	3		
BC125	Coupling type	5	50-150#BC125	80	10	15	70	110	179	102 ⁰ _{-0.054}	3		
BJ150	Disc type	1	Fixed side	50-201#BJ150	178	24	18	148	105	152	146 ^{+0.063} ₀	6	
			Free side	50-202#BJ150									48
		2	Fixed side	50-204#BJ150	194	24	—	164	—	—	—	—	
			Free side	50-205#BJ150									48
	Cup type	4	50-800#BJ150	123	3	12	120	125	192	110 ⁰ _{-0.054}	3		
BC150	Coupling type	5	50-150#BC150	90	10	17	80	140	217	124 ⁰ _{-0.063}	3.5		
BJ175	Disc type	3	Fixed side	50-201#BJ175	192	34	26	150	120	175	159	8	
			Free side	50-202#BJ175									54
		Cup type	4	50-800#BJ175	139	4	15	135	140	215	125 ⁰ _{-0.063}	4	
BC175	Coupling type	5	50-150#BC175	112	12	19	100	160	238	140 ⁰ _{-0.063}	4		
BJ200	Disc type	3	Fixed side	50-201#BJ200	215	35	28	170	140	200	181	10	
			Free side	50-202#BJ200									55
	Cup type	4	50-800#BJ200	154	4	16	150	160	250	140 ⁰ _{-0.063}	4		
BC200	Coupling type	5	50-150#BC200	132	12	19	120	185	272	165 ⁰ _{-0.063}	5		
BJ225	Disc type	3	Fixed side	50-201#BJ225	227	35	30	180	160	220	204	12	
			Free side	50-202#BJ225									55
	Cup type	4	50-800#BJ225	169	4	18	165	175	265	155 ⁰ _{-0.063}	4		
BJ250	Disc type	3	Fixed side	50-201#BJ250	240	38	34	190	180	245	222	12	
			Free side	50-202#BJ250									58
BJ300	Disc type	3	Fixed side	50-201#BJ300	262	45	38	205	205	275	256	12	
			Free side	50-202#BJ300									70

① Prepared hole diameter.

Remarks: 1. Upon request from the user, NTN will machine the inside diameter and width according to the shaft to be installed. Contact NTN Engineering.

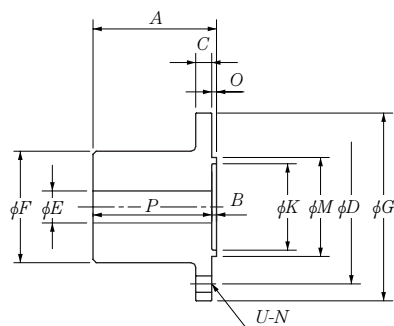

Fig. 4
Cup (BJ75-225)
400, 800 series

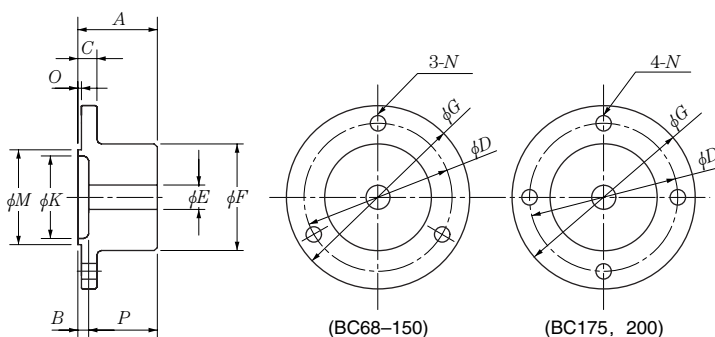
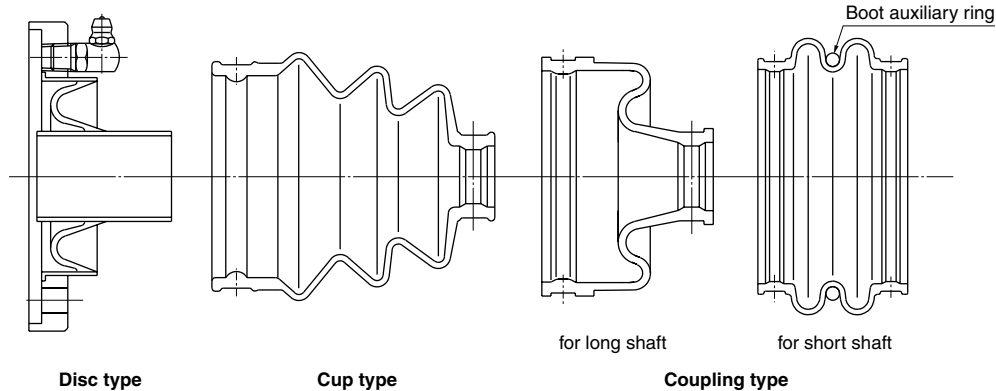

Fig. 5
Coupling (BC68-200)
150 series

Inside dia.				Bolt hole				Dimensional unit mm	
φ E	φ H	φ K	S	φ D	U	N	W	GD ² × 10 ⁻³ kg · m ²	Mass kg
0	—	48	—	86 ± 0.15	—	φ 8.2	—	4.68	1.2
—	45	50		66 ± 0.15		M8		3.96	1.76
0	—	54		97 ± 0.15	3	φ 10.2	16	3.80	1.62
								18.4	4.97
0	—	62		110 ± 0.15	—	φ 12.2	16	18.2	4.78
								10.6	2.80
—	55	63		80 ± 0.2	—	M8	16	9.04	2.0
								17.4	2.9
0	—	62		110 ± 0.15	3	φ 12.2	16	9.73	3.43
								9.28	3.14
0	—	72		125 ± 0.15	—	φ 14.3	16	43.0	8.35
								42.2	7.96
30	75	70		106 ± 0.2	—	M10	20	20.8	4.02
—		34.8						4.2	
48	—	80		150 ± 0.2	3	φ 14.3	20	38.5	7.53
								36.6	6.85
0	—	90		124 ± 0.2	—	M12	24	144	14.7
								140	14.3
—	85	96		165 ± 0.2	6	φ 14.3	24	90.4	10.2
								78.3	6.8
58	—	95		185 ± 0.2	—	φ 16.4	24	83.4	11.9
								79.5	10.8
40	95	110		139.7 ± 0.2	—	M14	24	297	21.9
								292	21.3
40	—	125	203 ± 0.2	6	φ 17	24	164	15.3	
							159	14.4	
50	—	130	215 ± 0.2	6	φ 18.4	24	236	17.4	
							348	18	
60	110	130	159 ± 0.2	—	M12	24	319	21.5	
							311	20.4	
50	—	145	233 ± 0.2	6	φ 19	24	452	24.9	
							675	28	
60	130	150	180 ± 0.2	—	M12	24	542	30.0	
							514	28.3	
50	—	135	228 ± 0.2	6	φ 21	24	683	32.9	
							933	40.9	
70	138	160	197 ± 0.2	—	M16	24	912	39.1	
							1690	57.1	
80	155	180	225.4 ± 0.2	—	M16	24	1645	54.4	
							—	—	

Boot



Boot Band

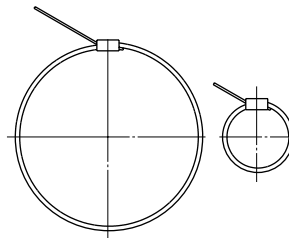

For cup, coupling

Applicable joint	Type	Parts number							
		Boot	Boot retainer plate	Boot retainer plate	Boot band (large)	Boot band (small)	Boot auxiliary ring	Set ①	
BC68	Coupling type	Short shaft	17-11#BC68	—	—	20-1#BJ75	—	98-4#BJ68	99-120#BJ68
		Long shaft	17-31#BJ68	—	—	20-1#BJ75	20-2#BJ75	—	99-17#BJ68
BJ75	Disc type	Short shaft	18-1#BJ75	19-1#BJ75	24-3#BJ75	—	—	—	99-301#BJ75
		Long shaft	17-30#BJ75	—	—	20-1#BJ75	20-2#BJ75	—	99-102#BJ75
BC75	Coupling type	Short shaft	17-10#BC75	—	—	20-1#BJ75	20-2#BJ75	98-5#BJ75	99-120#BJ75
		Long shaft	17-30#BJ75	—	—	20-1#BJ75	20-2#BJ75	—	99-37#BJ75
BC87	Coupling type	Short shaft	17-10#BC87	—	—	20-1#BJ100	—	98-7#BJ87	99-120#BJ87
		Long shaft	17-39#BJ87	—	—	20-1#BJ100	20-2#BJ100	—	99-27#BJ87
BJ95	Disc type	Short shaft	18-1#BJ95	19-1#BJ95	24-3#BJ75	—	—	—	99-301#BJ95
		Long shaft	17-16#BJ95	—	—	20-1#BJ100	20-2#BJ100	—	99-15#BJ95
BJ100	Cup type	Short shaft	17-4#BJ100	—	—	20-1#BJ100	20-2#BJ100	—	99-16#BJ100
		Long shaft	17-21#BJ100	—	—	20-1#BJ100	20-2#BJ100	98-7#BJ100	99-17#BJ100
BC100	Coupling type	Short shaft	17-10#BC100	—	—	20-1#BJ100	—	—	99-301#BJ100
		Long shaft	17-21#BJ100	—	—	20-1#BJ100	20-2#BJ100	—	99-17#BJ100
BJ125	Disc type	Short shaft	18-1#BJ125	19-1#BJ125	24-3#BJ75	—	—	—	99-16#BJ125
		Long shaft	17-15#BJ125	—	—	20-1#BJ150	20-2#BJ150	—	99-16#BJ125
BC125	Coupling type	Short shaft	17-10#BC125	—	—	20-1#BJ150	20-2#BJ150	98-16#BJ125	99-30#BJ125
		Long shaft	17-19#BJ125	—	—	20-1#BJ150	20-2#BJ150	—	99-17#BJ125
BJ150	Disc type	Short shaft	18-1#BJ150	19-1#BJ150	24-3#BJ75	—	—	—	99-301#BJ150
		Long shaft	17-4#BJ150	—	—	20-1#BJ150	20-2#BJ150	—	99-16#BJ150
BC150	Coupling type	Short shaft	17-10#BC150	—	—	20-1#BJ150	20-2#BJ150	98-8#BJ150	99-30#BJ150
		Long shaft	17-6#BJ150	—	—	20-1#BJ150	20-2#BJ150	—	99-17#BJ150
BJ175	Disc type	Short shaft	18-1#BJ175	19-1#BJ175	24-3#BJ75	—	—	—	99-301#BJ175
		Long shaft	17-7#BJ175	—	—	20-2#BJ550	20-2#BJ225	—	99-28#BJ175
BC175	Coupling type	Short shaft	17-10#BC175	—	—	20-3#BJ250	—	98-21#BJ175	99-30#BJ175
		Long shaft	17-5#BJ175	—	—	20-3#BJ250	20-2#BJ350	—	99-27#BJ175
BJ200	Disc type	Short shaft	18-1#BJ200	19-1#BJ200	24-3#BJ75	—	—	—	99-30#BJ200
		Long shaft	17-3#BJ200	—	—	20-1#BJ225	20-2#BJ225	—	99-3#BJ200
BC200	Coupling type	Short shaft	17-10#BC200	—	—	20-1#BJ400	—	98-16#BJ200	99-30#BJ200
		Long shaft	17-1#BJ200	—	—	20-1#BJ400	20-2#BJ350	—	99-17#BJ200
BJ225	Disc type	Short shaft	18-1#BJ225	19-1#BJ225	24-3#BJ75	—	—	—	99-301#BJ225
		Long shaft	17-1#BJ225	—	—	20-1#BJ225	20-2#BJ225	—	99-16#BJ225
BJ250	Disc type	Short shaft	18-1#BJ250	19-1#BJ250	24-3#BJ75	—	—	—	99-301#BJ250
		Long shaft	18-1#BJ300	19-1#BJ300	24-3#BJ75	—	—	—	99-301#BJ300

① The set for disc comprises an assembly that consists of one boot, one boot fixing plate, and two grease nipples.

The set for cup comprises one boot, one boot band (large) and one boot band (small).

The short shaft set for coupling comprises one boot, one auxiliary ring and two boot bands.

The long shaft set comprises one boot, one boot band (large) and one boot band (small).

Remarks: Depending on an applicable joint number, the form of boot can differ from an illustrated one.

When fastening a boot band, use a special fastening tool. For the form and part description of the tool, see page 60.

Hexagon Headed Bolt/Spring Washer/Hexagon Nut

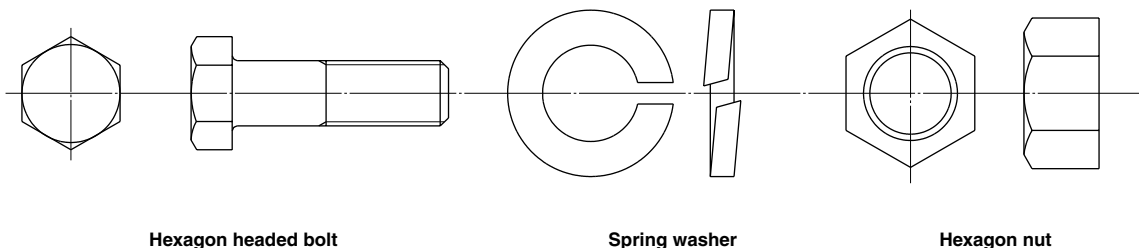

Hexagon headed bolt

Spring washer

Hexagon nut

Applicable joint	Type	Parts number									
		Small hexagon headed bolt	Hexagon headed bolt	Spring washer (#2)	Spring washer	Hexagon nut	Set ①				
BC68	Coupling type	51-5#BJ68	—	57-10#BJ75	52-5#BJ75	—	99-22#BJ68				
	Disc type	51-20#BJ75					99-31#BJ75				
BJ75	Cup type	51-23#BJ75					57-10#BJ125	52-5#BJ125	99-32#BJ75		
							BC75	Coupling type	51-6#BJ87	57-10#BJ150	52-5#BJ150
BC87	Disc type	51-20#BJ95					57-10#BJ75	—	99-21#BJ95		
BJ95		Cup type					51-6#BJ87	57-10#BJ150	52-5#BJ150	99-22#BJ87	
BJ100	Coupling type	51-6#BJ100					57-10#BJ175	52-5#BJ175	—	99-22#BJ100	
BC100		Disc type					51-20#BJ125	57-10#BJ125	—	99-21#BJ125	
BJ125	Cup type	51-6#BJ100					57-10#BJ175	52-5#BJ175	—	99-22#BJ100	
	BC125	Coupling type					51-20#BJ150	57-10#BJ150	—	99-21#BJ150	
BJ150	Disc type	51-20#BJ150					57-10#BJ175	52-5#BJ175	—	99-32#BJ150	
	Cup type	51-6#BJ100					57-10#BJ175	52-5#BJ175	—	99-22#BJ150	
BC150	Coupling type	51-9#BJ150					57-10#BJ250	52-5#BJ250	—	99-22#BJ150	
BJ175	Disc type	—					51-20#BJ175	57-10#BJ175	—	99-21#BJ175	
	Cup type	—					51-30#BJ175	57-10#BJ250	—	99-32#BJ175	
BC175	Coupling type	51-15#BJ175					—	57-10#BJ350	52-5#BJ350	—	99-22#BJ175
BJ200	Disc type	—					51-20#BJ200	57-10#BJ150	—	—	99-21#BJ200
	Cup type	—					51-13#BJ300	57-10#BJ350	—	52-15#BJ350	99-32#BJ200
BC200	Coupling type	51-8#BJ200					—	57-10#BJ400	52-5#BJ400	—	99-22#BJ200
BJ225	Disc type	—					51-20#BJ225	57-10#BJ150	—	—	99-21#BJ225
	Cup type	—	51-27#BJ225	57-10#BJ400	—	52-15#BJ400	99-32#BJ225				
BJ250	Disc type	—	51-20#BJ250	57-10#BJ250	—	—	99-21#BJ250				
BJ300		—	51-20#BJ300	—	—	—	99-21#BJ300				

① The set for disc comprises six hexagonal head bolts and six spring washers.

The sets for cup comprise:

Applicable joint BJ75-BJ125: six hexagonal head bolts, six spring washers, and six hexagonal nuts

Applicable joint BJ150-BJ225: 12 hexagonal head bolts, 12 spring washers, and 12 hexagonal nuts

The sets for coupling comprise:

Applicable joint BC68-BC150: six small hexagonal head bolts, six spring washers, and six small hexagonal nuts

Applicable joint BC175-BC200: eight small hexagonal head bolts, eight spring washers, and eight small hexagonal nuts

Diagrams of Applications

The examples below illustrate special applications not covered as standard series in our catalogs.

NTN offers an ideal constant velocity joint that is optimized for your intended machine and/or operating conditions. When wanting a constant velocity joint for a very unique application, contact NTN Engineering.

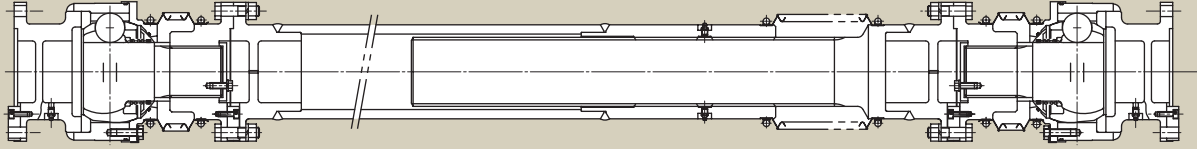

Continuous casting equipment (very demanding atmosphere) (HTJ220)

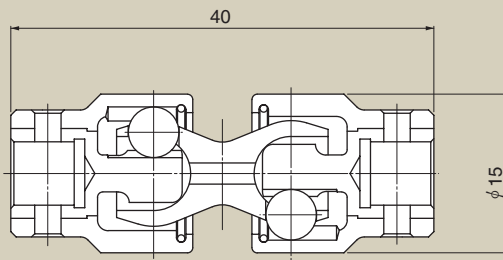

For radio-controlled boat (TBJ8)

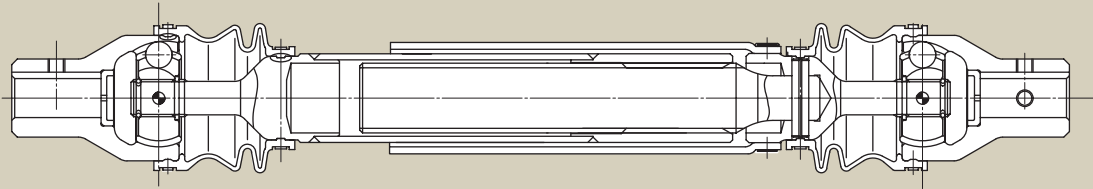

For printing machinery (BJ50)

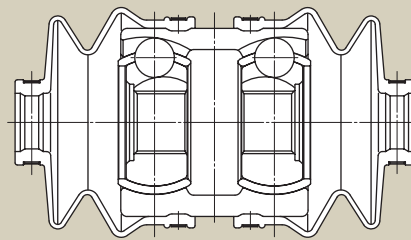

For axle on sprinkling vehicle (BJ75 double-drum)

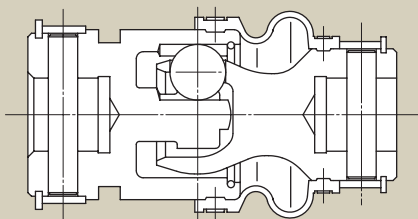

For axle on golf-cart (TBJ20)

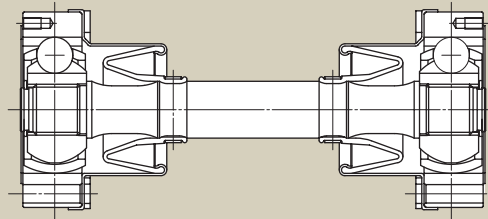

For custom-made special vehicles (LJ109)

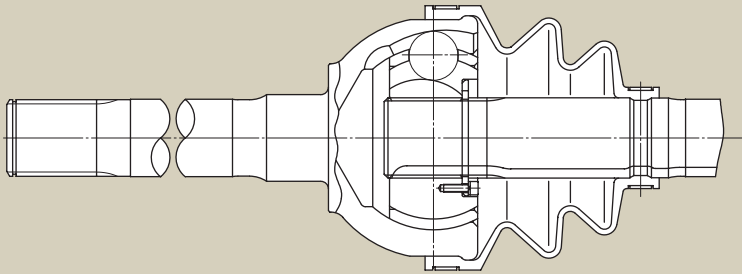

For vehicle (drive axle)
(BJ175)

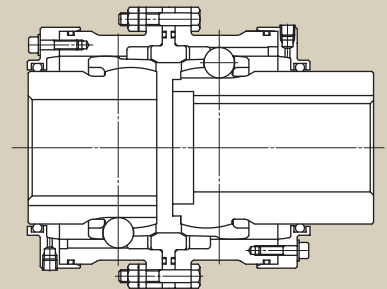

12-ball coupling
(BC150)

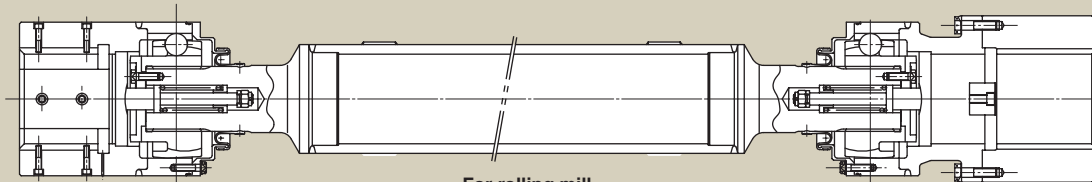

For rolling mill
(DOJ725)

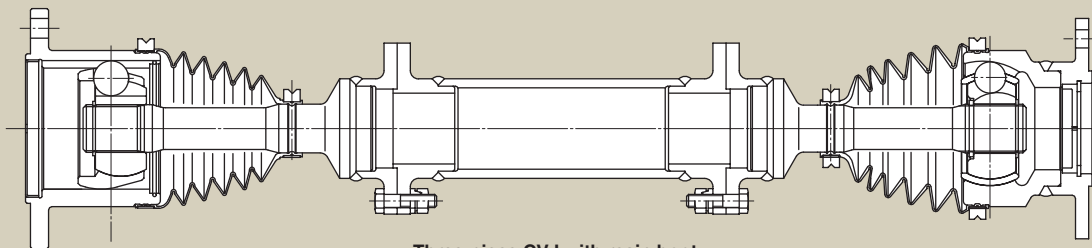

Three-piece CVJ with resin boot
(DOJ100+BJ100)

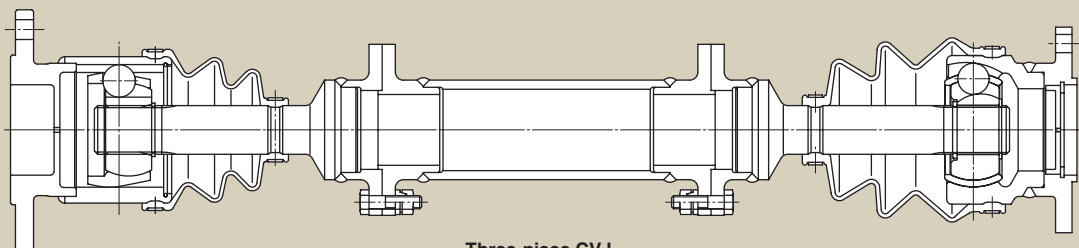

Three-piece CVJ
(DOJ100+BJ100)

Usage and Handling

1. Installation Procedure

(1) Checking the installation dimensions

Check that the mounting span on the machine coincides with the length of the constant velocity joint (see **Fig. 1**).

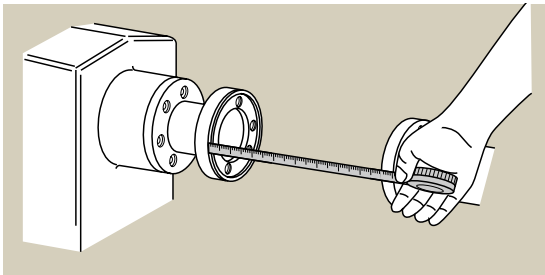

Fig. 1

(2) Filling the grease

Fill the grease included with the constant velocity joint to 1/2 to 1/3 as much as the undercut space capacity of the mounting flange hub (see **Fig. 2**).

CAUTION

- The grease can cause eye inflammation to human eyes. When handling it, wear protective goggles.
- ※ If it has contaminated the eyes, rinse with clean water, and immediately seek medical attention.
- The grease can cause skin inflammation. When handling it, wear protective gloves.
- ※ If it has touched skin, wash it off thoroughly with water and soap.

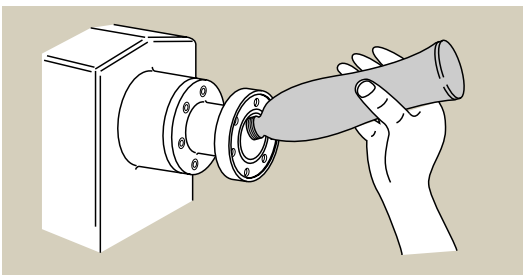

Fig. 2

(3) Installing the joint

Install the joint to the flange with the included bolts (see **Fig. 3**). Tighten the bolts with a torque equivalent to JIS bolt strength category 8.8. The recommended bolt tightening torques are listed in **Table 1**.

Retighten the bolts immediately after, and one month after commissioning the operation with the joint.

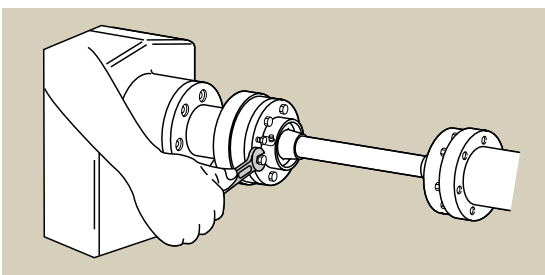

Fig. 3

(4) Cautions for installation work

- Avoid hitting the CVJ with a foreign object or exerting an impact force onto the CVJ.
- Limit the angle to the operating angle range at static state in order to avoid damage on the boot.
- Be careful not to damage or deform the boot and boot band.
- The free-side CVJ proper can be readily come off the shaft. Be careful not to allow it to be released from the shaft.
- Be sure to enclose the CVJ with a safety cover. If splash of oil, even in a smallest amount, to the surrounding is unacceptable, be sure to incorporate a cover that contains oil splash.
- In the case of a fixed disc type, the joint assembly can be easily mounted if the free side is mounted first. If the mounting span is short and mounting of the joint assembly is difficult, shift the machine as necessary. Install the packing to a correct position, being careful not to damage or deform it. While tightening the bolts, be careful not to deform the metal ring on boot.
- For a coupling type, fit the O-ring to a correct position, being careful not to damage it (see **Fig. 4**).

DANGER

- Do not approach the running joint.

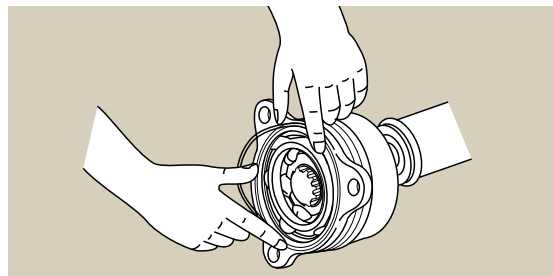

Fig. 4

Table 1

Nominal bolt size	Tightening torque ^① N · m	
M 8	19.6	to 24.5
M10	39.2	to 49.0
M12	73.5	to 83.4
M14	118	to 127
M16	181	to 201
M18	235	to 275
M20	353	to 392
M22	490	to 539
M24	588	to 686
M27	883	to 981
M30	1 270	to 1 370

① Data is for bolt strength classification JIS 8.8.

2. Precautions for Operation

(1) Operating environment

The seal member of constant velocity joint is composed of chloroprene rubber. Though varying depending on the operating conditions, the recommended atmospheric temperature range, as a guideline, should be $-10\text{--}60^{\circ}\text{C}$. When intending a temperature range different from this, contact NTN Engineering.

Also, when intending to use the CVJ in an environment where oil, organic solvent, chemical or gas is present, contact NTN Engineering.

(2) Grease leakage

When grease has leaked from the mounting section of the CVJ or the tightening section of the boot band, replenish grease and exercise an appropriate measure, such as retightening of the bolts, and replacement of the boot band, packing and O-ring.

When replacing the boot band, be sure to use a fresh one.

(3) Replenishing or replacing grease

When replenishing grease to the CVJ, avoid overfilling to prevent the boot from being deformed.

To replace grease, remove the old grease and fill fresh grease. After degreasing & cleaning of the joint, be sure to apply grease to the sliding surface within the joint and the splining.

Use the grease dedicated to NTN constant velocity joints. This grease is lead-free eco-friendly grease.

(4) Backlash

The backlash (θ_s) on NTN constant velocity joints is as defined below:

Joint with standard joined shaft (θ_s): $40' - 1^{\circ}20'$

Standard intermediate spline joined shaft (θ_s): $50' - 1^{\circ}40'$

When wanting a joint of a smaller backlash, contact NTN Engineering.

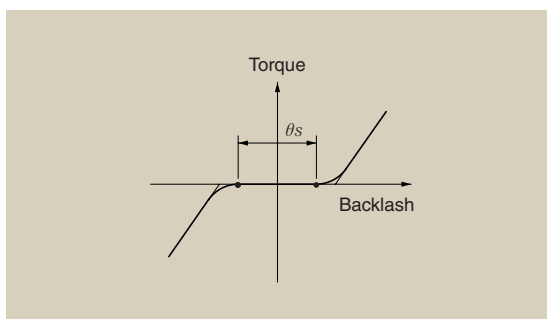

(5) Vibration

Be sure to provide a difference of 30% or more relative to a characteristic vibration value of torsional vibration or flexural vibration (whirling speed).

Whirling speed N

$$N = 0.12 \times 10^9 \frac{\sqrt{d_0^3 + d_1^3}}{l^2} \text{ rpm}$$

l : center-to-center distance on the CVJ mm

d_0, d_1 : outside diameter, inside diameter, of shaft (steel pipe) mm

3. Welding Procedure

(1) Welding shaft head to steel pipe

1. Weld the steel pipe with the butting form shown below.

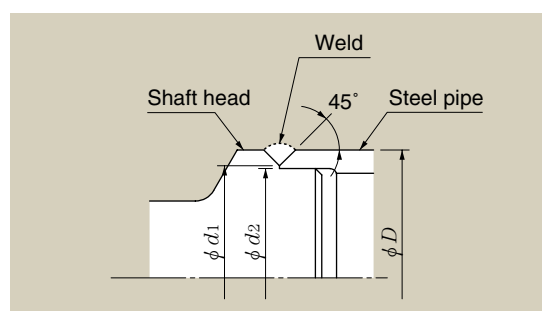

Recommended weld dimensions with steel pipe

ϕD	ϕd_1	ϕd_2
$\phi 48.6$	$\phi 42.6$	$\phi 41.6 \begin{smallmatrix} 0 \\ -0.05 \end{smallmatrix}$
$\phi 60.5$	$\phi 53$	$\phi 51.7 \begin{smallmatrix} 0 \\ -0.05 \end{smallmatrix}$
$\phi 76.3$	$\phi 67$	$\phi 66 \begin{smallmatrix} 0 \\ -0.05 \end{smallmatrix}$
$\phi 89.1$	$\phi 81.5$	$\phi 79.5 \begin{smallmatrix} 0 \\ -0.05 \end{smallmatrix}$
$\phi 101.6$	$\phi 90$	$\phi 87 \begin{smallmatrix} 0 \\ -0.054 \end{smallmatrix}$
$\phi 139.8$	$\phi 125$	$\phi 123 \begin{smallmatrix} 0 \\ -0.063 \end{smallmatrix}$

2. During welding work, perform preheating and postheating.
3. After welding work, check the bend of shaft.

TIR should be 0.5mm or less with both centers supported

- If the intended application requires only RPM, the joint assembly can be used without problem by correcting the bend on shaft. If high speed application is intended, the shaft must be corrected for optimal dynamic balance.

Balance quality: JIS G 16 (guideline)

(2) Welding material

Low hydrogen type electrode 55 kg class for high strength steel (JIS Z 3212, D 5316)

CAUTION

Use care when welding. Take steps to insure good welding techniques.

4. Assembly

(1) Fixed Disc Type

Fixed side CVJ

Step 1 Press-fit the boot into the boot retainer plate. **(Photo 1)**

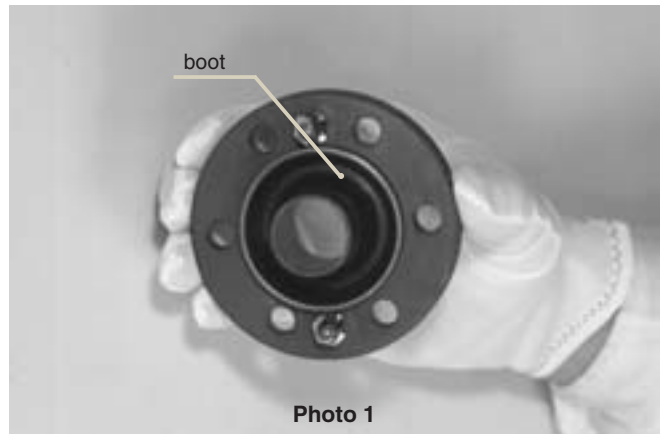

Step 2 Inject NTN provided authorized grease into the boot. **(Photo 2)**



Step 3 Install the boot to the shaft, and fit the square-section circlip into the groove on the shaft ❶. **(Photo 3)**

❶ For installation procedure with the square-section circlip, see Sec. 4.5 on page 59.

Remarks: Joint BJ175–300 lack the square-section circlip.

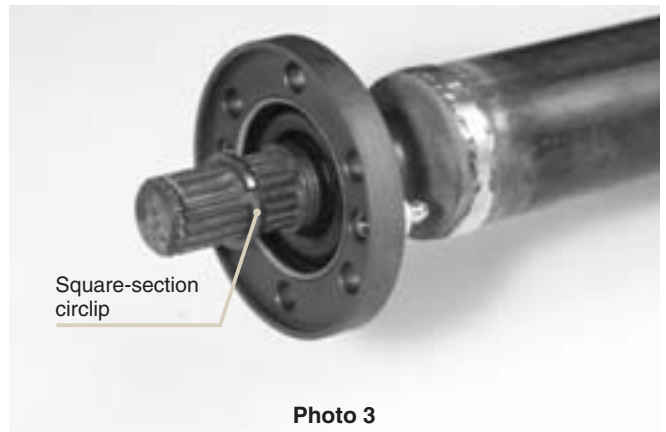

Step 4 Seat the packing inside the boot. **(Photo 4)**

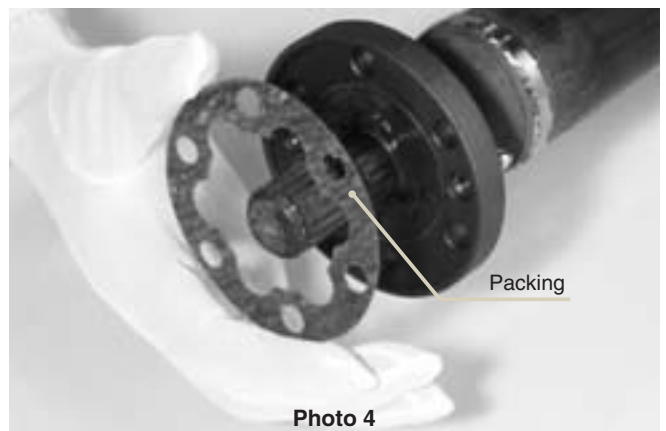

Step 5 Inject NTN provided authorized grease into the joint proper. **(Photo 5)**

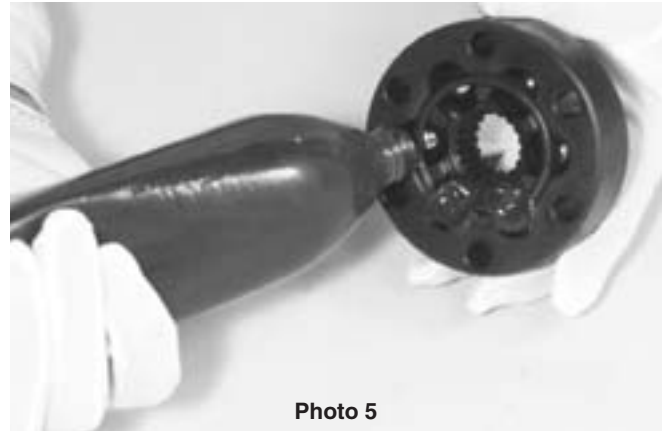

Photo 5

Step 6 Apply NTN provided authorized grease to the splines on the shaft. **(Photo 6)**



Photo 6

Step 7 Procedure for **BJ75-150**
Force the CVJ proper all the way in until it touches the circlip (see **Photo 6**), and lock it with an E-ring or C-ring. **(Photos 7 and 8)**

CAUTION

Handle the E-ring or C-ring with care. The spring force in the ring can cause it to fly off if it slips during installation.

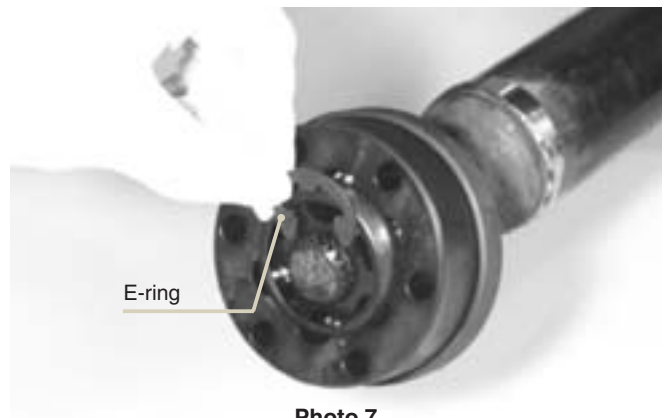

Photo 7

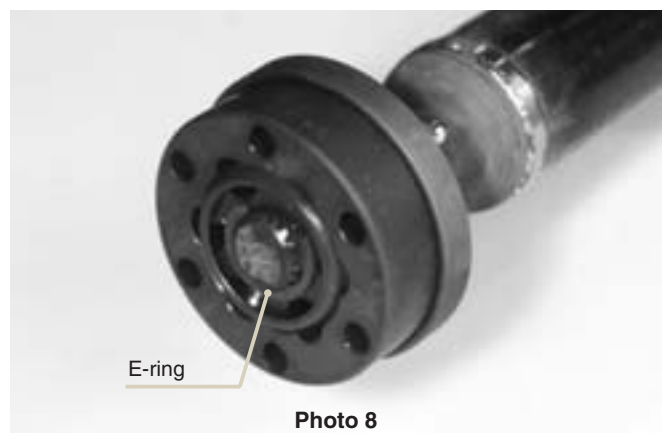
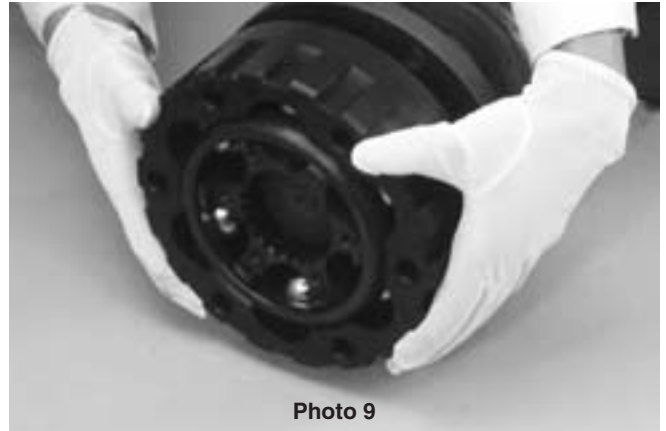

Photo 8

Usage and Handling

Step 7 Procedure for BJ175-300

- (1) Orient the groove on the outer face of the outer race to the outward direction. Mount the joint assembly on the shaft until the end face of the inner race reaches the groove for retainer plate on the shaft. **(Photo 9)**



- (2) Install the splined retainer plate so that its splines mesh with the splines on the shaft. **(Photo 10)**



- (3) Align the tapped holes to those on the inner race (also, align the teeth of splines on the shaft with tooth spaces on the retainer plate), then lock the retainer plate with the hexagon headed bolts. **(Photo 11)**

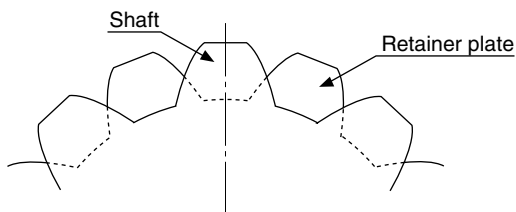

- Step 8 Inject NTN provided authorized grease into the mounting portion on the CVJ assembly. **(Photo 12)**

Free side CVJ

For assembling the free side CVJ, observe the assembly procedure for the fixed side CVJ except for step 3 (installation of the square-section circlip) and step 7 (installation of the E-ring or locking of the retainer plate).



(2) Fixed Cup/Drum**Fixed side CVJ**

Step 1 Place the boot bands (both large diameter and small diameter) over the shaft. **(Photo 13)**



Photo 13

Step 2 Fit the boot over the shaft. Fit the square-section circlip into the groove on the shaft **①**. **(Photo 14)**

① For installation procedure with the square-section circlip, see **Sec. 4.5 on page 59**.

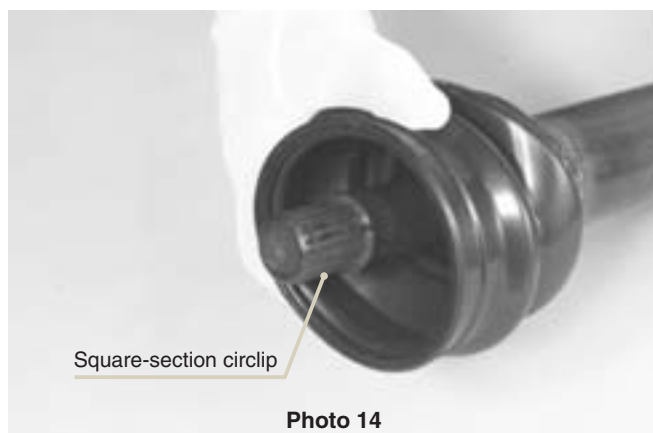

Photo 14

Step 3 Inject NTN provided authorized grease into the CVJ assembly. **(Photo 15)**



Photo 15

Step 4 Fill NTN provided authorized grease into the boot (about 1/3 to 1/2 as much as the space). **(Photo 16)** Apply NTN grease for constant velocity joints to the splines on the shaft.



Photo 16

Usage and Handling

Step 5 Mount the CVJ assembly onto the shaft until the inner race is against the square section circlip (see **Photo 17**), and lock it with a C-ring. (**Photo 18**)

CAUTION

Carefully handle a C-ring. The ring can fly owing to its spring force.

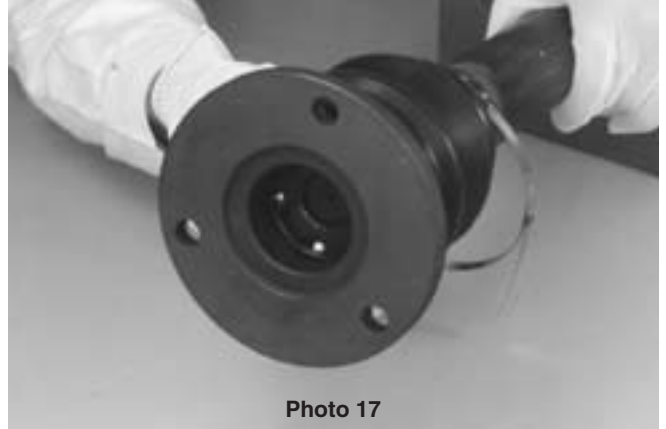

Photo 17

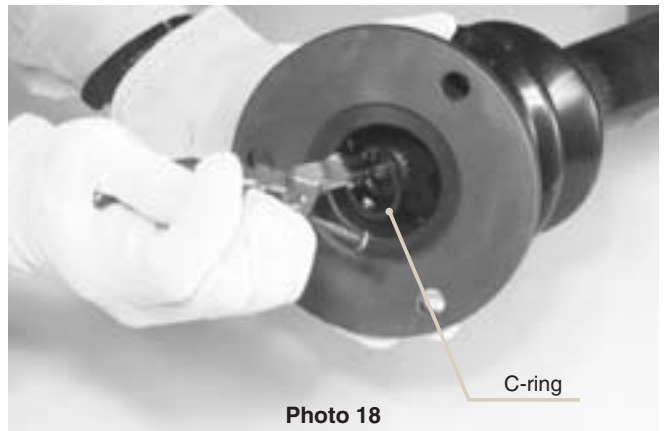

Photo 18

Step 6 Inject NTN provided authorized grease into the mounting portion on the CVJ assembly. (**Photo 19**)



Photo 19

Step 7 Fit the boot into the boot retaining grooves on the shaft and outer race. Fit the boot bands over the boot and fasten them^①. (**Photo 20**)

① For fastening the boot bands, see Sec. 4.6 and 4.7 on page 60.

Free side CVJ

For assembling the free side CVJ, observe the assembly procedure for the fixed side CVJ except for step 2 (installation of the square-section circlip) and step 5 (installation of the C-ring).



Photo 20

(3) Coupling

Step 1 Place the boot bands (both large diameter and small diameter) over the shaft, and shift them to the steel pipe side. Then, fit the boot over the shaft. (**Photo 21**)



Photo 21

Step 2 Fit the square-section circlip into the groove on the shaft. (**Photo 22**)

① For installation procedure with the square-section circlip, see Sec. 4.5 on page 59.



Photo 22

Step 3 Inject NTN provided authorized grease into the CVJ assembly. (**Photo 23**)



Photo 23

Step 4 Fill NTN provided authorized grease into the boot (about 1/3 to 1/2 as much as the space). (**Photo 24**) Apply NTN grease for constant velocity joints to the splines on the shaft.



Photo 24

Usage and Handling

Step 5 Mount the CVJ assembly onto the shaft until the inner race is against the square section circlip, and lock it with a C-ring. **(Photo 25)**

CAUTION

Handle the C-ring with care. The spring force in the ring can cause it to fly off if it slips during installation.

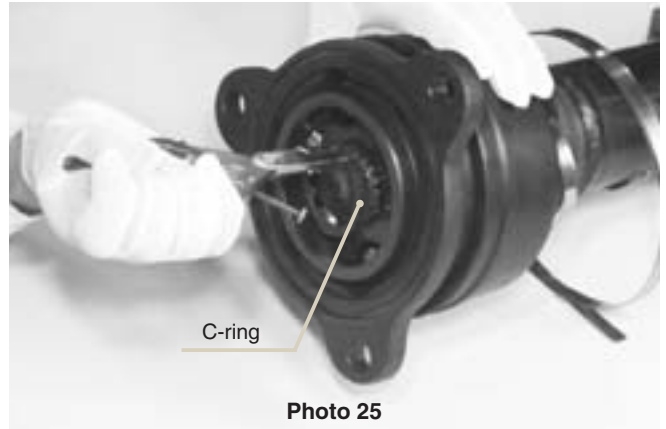

Step 6 Inject NTN provided authorized grease into the mounting portion on the CVJ assembly. **(Photo 26)**



Step 7 Fit the boot into the boot retaining grooves on the shaft and outer race. Fit the boot bands over the boot and fasten them ❶. **(Photo 27)**

❶ For fastening the boot bands, see Sec. 4.6 and 4.7 on page 60.



(4) CVJ Assembly (D0 series, C0 series, M0 series)

The inside of CVJ assembly is coated with Molycoat. Before using the joint, fill with NTN provided authorized grease so that it is uniformly spread within the inside of CVJ assembly. **(Photo 28)**

CAUTION

Use care when disassembling the joint assembly as there may be sharp edges, particularly on the cage ball sockets.



(5) Special tools for Square-section Circlip and Installation Procedure

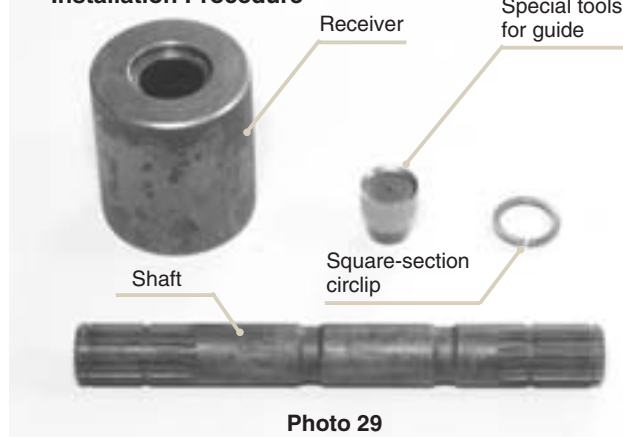

Photo 29

Remarks : The sizes of the receiver and special tools for guide must comply with the associated joint numbers (see Fig. 1 and Fig. 2).

Tool A for Square-section circlip (major dimensions)

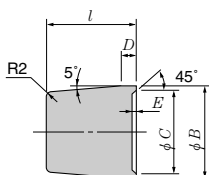

Table 1 mm

Applicable joint	l	ϕB	ϕC	D	E
BJ 75	22	22.5	20.5	4	2
BJ 95	25	27	25	5	2
BJ 100	25	30	28	5	2
BJ 125	40	37	35	5	2.5
BJ 150	35	46	44	5	2.5

Tool B for Square-section circlip (major dimensions)

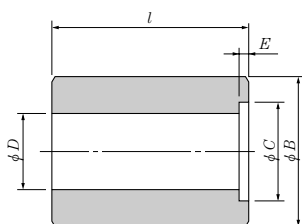

Table 2 mm

Applicable joint	l	ϕB	ϕC	ϕD	E
BJ 75	70	60	30	23.5	4
BJ 95	80	65	35	27.5	4
BJ 100	80	65	40	30.5	4
BJ 125	100	65	47	37.5	4
BJ 150	100	70	55	47.5	4

WARNING

- Be sure to wear a set of protective goggles while fitting a square-section circlip.

Procedure

Step 1 Place a square-section circlip onto the receiver. (Photo 30)



Photo 30

Step 2 Insert the guide a special tools into the circlip. (Photo 31)



Photo 31

Step 3 Place the shaft into the guide a special tools and using a vinyl or wood mallet, drive the shaft into the circlip (Photo 32) until it is seated in the groove (Photo 33).



Photo 32

Usage and Handling



Photo 33

(6) Boot Band Fastening Jig

Photo 34 illustrates the boot band fastening jig.



Photo 34 (Part number: 98-1 #BJ150)

(7) Precautions for fastening boot bands

- 1) Securely fasten the boot band to avoid leakage of grease.
- 2) Carefully fasten the boot band so as not to damage or deform it.
- 3) Carefully fold the boot band fastening portion so that the lip of band does not protrude.
- 4) Handle the boot band carefully as there may be sharp edges that could cause injury.
- 5) Deforming the boot band or tightening a boot band obliquely can damage the boot. Avoid such a practice.

CAUTION

- Wear protective gloves to avoid injury of a finger with an edge on boot band.

5. Storage

When storing NTN constant velocity joints, observe the following instructions.

- 1) Store in a clean, dry location.
- 2) To prevent the boots from being deformed, avoid storing the assemblies in an unstable state (**Fig. 1**). Store them in a stable, horizontal position (**Fig. 2**).
- 3) Protect the boots, etc., with a cover.
- 4) Do not stack cardboard boxes containing constant velocity assemblies. The additional weight may deform the boxes and damage to the contents may occur.
- 5) When using a constant velocity joint that has been stored for a prolonged period, elaborately inspect the state of boot and grease.

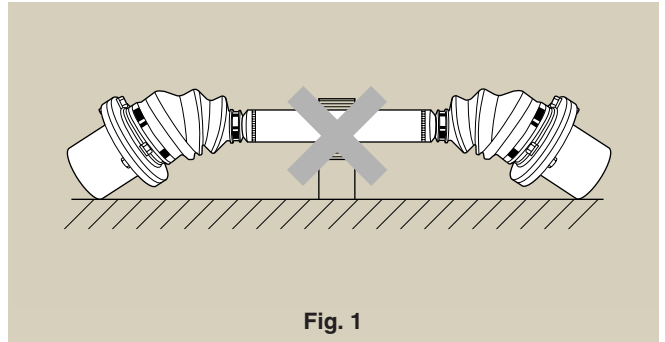

Fig. 1

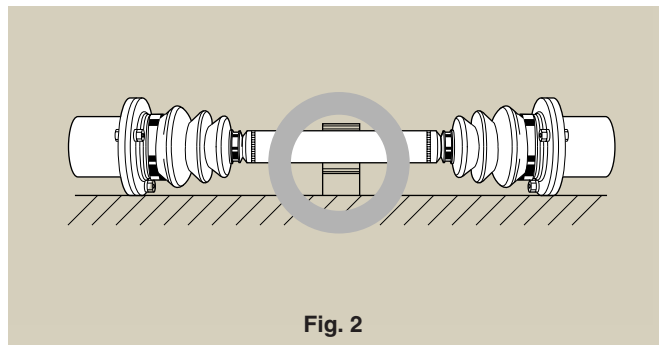

Fig. 2

About Service Conditions Confirmation Sheet

To confirm the service conditions of your joint assembly, use the "Service Conditions Confirmation Sheet" on page 61.

Select an optimal NTN constant velocity joint product from a range of NTN constant velocity joint series after thoroughly considering a user's intended operating conditions and intended applications.

Service Conditions Confirmation Sheet

NTN CONSTANT VELOCITY JOINT SERVICE CONDITIONS CONFIRMATION SHEET

Company Name				Date
Machine			Area	
Service conditions				
1. Kind of prime motor	Motor	AC, DC	Output; <input type="text"/> kW / <input type="text"/> HP / <input type="text"/> r/min	
	Engine	Gasoline	No. of cylinders; <input type="text"/> Max. output <input type="text"/> PS / <input type="text"/> r/min	
		Diesel	Max. torque <input type="text"/> kgf·m / <input type="text"/> r/min	
2. Number of joints to be driven per unit	<input type="text"/>			
3. Joint rotation speed	Constant <input type="text"/> r/min Variable <input type="text"/> to <input type="text"/> r/min			
4. Rotating direction	One direction Forward/reverse			
5. Transmission torque	Constant <input type="text"/> kgf·m			
	Variable Max. <input type="text"/> to Normal <input type="text"/> to Min. <input type="text"/> kgf·m			
6. Shock	None Approx. <input type="text"/> % against the rated torque of driving source			
7. Service hours	24 hrs/day constantly <input type="text"/> hrs/day Others <input type="text"/>			
8. Joint installation drawing				
Driving end (<input type="text"/>) Follower end (<input type="text"/>) Key groove width <input type="text"/> x depth <input type="text"/> Key groove width <input type="text"/> x depth <input type="text"/>				
[Remarks] When the above drawing is not applicable, make a special study. When the installation/operation position (L and X, Y) changes, confirm the changed position (amount) and the loading condition at that position.				
9. Installation direction	Horizontal Vertical			
10. Expansion and angle variation while torque is transmitted	No Yes			
11. Outside diameter limit	No Yes up to <input type="text"/> mm			
12. Place and atmosphere	Indoor Outdoor Temp <input type="text"/> °C Others <input type="text"/>			
13. Kind and joint No. of the joints currently used	None Kind and joint No. <input type="text"/>			
14. Special notes:				
----- ----- ----- -----				

Remarks: 1. Upon receiving your service conditions, NTN will recommend the best suited joint number.
 2. Upon receiving the user's instructions about the dimensions of mounting flange hub (inside dia. key groove dimensions, etc.), NTN will machine the hub.