

NTN[®]

**Sealed Four Row Tapered Roller Bearings
for Rolling Mill Roll-Necks
[CROU..LL Type]**

ULTAGE

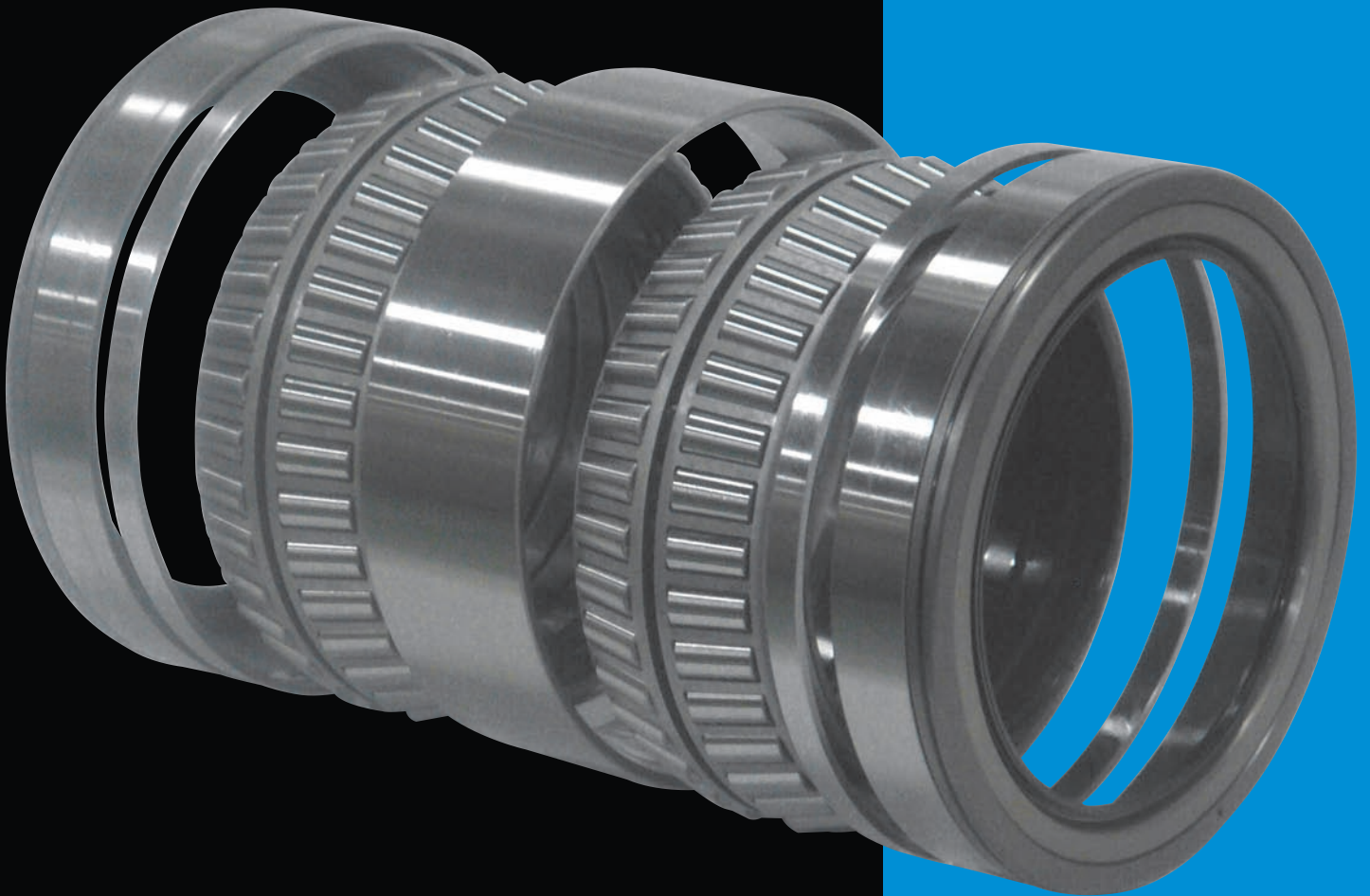

ULTAGE[®]

CAT. No. 3801/E

ULTAGE®

Load capacity
40% increase

Load resistance
Twice as great

Sealing performance
50% reduction in water intrusion volume

Sealed Four Row Tapered Roller Bearings for Rolling Mill Roll-Necks [CROU..LL Type]

The ULTAGE series sealed four row tapered roller bearings (CROU..LL type) are new standard series products especially developed to satisfy the "high load capacity", "high load resistance performance" and "high sealing performance" required for steel mill roll-neck applications and to improve reliability through long life design.

High load capacity

- Compact seal design helps maximize bearing side volume.
- Maximization in the size and number of rollers helps realize high load capacity.

Longer bearing life

High load resistance performance

- Newly developed crowning helps reduce and ensure uniform contact pressure.
- World's highest level in load resistance performance.

Improved sealing performance

- Newly developed seal lip design significantly reduces water intrusion volume.
- Fluoro-rubber seal boasts more positive sealing performance.

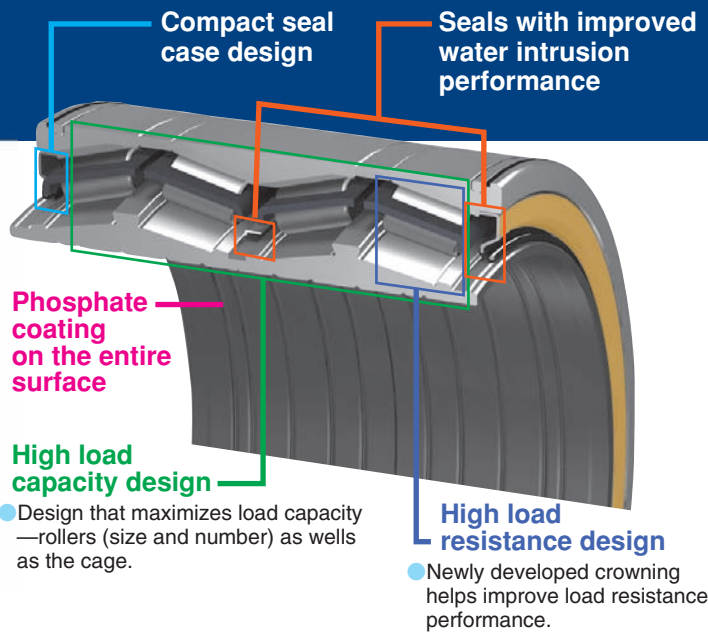

Features

1. High load capacity design —the world's highest level

Maximum size and number of rollers help realize high load capacity and longer life.

2. High load resisting design —the world's highest level Patent pending

Assurance of uniform contact pressure on rolling elements within bearings and against outside loads has helped greatly enhance load resistance performance.

3. Compact high sealing design Patent pending

"High sealing" fluoro-rubber seals, boasting a minimized seal volume, are adopted as standard. Through optimization of the tightening force of the main lip and the provision of a shielding arrangement against foreign substances, the water intrusion volume has been reduced by more than 50%: at the same time, the sub lip helps prevent the outflow of grease.

4. Long-life grease as standard

The bearing is prefilled with long-life grease. A rinsing and/or grease prefilling procedure is not necessary when the bearing is installed on the side of the machine.

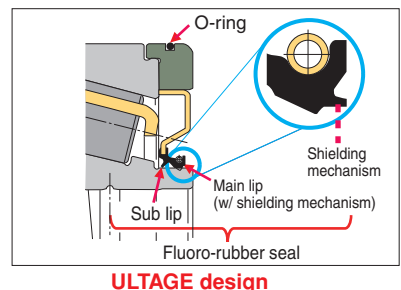
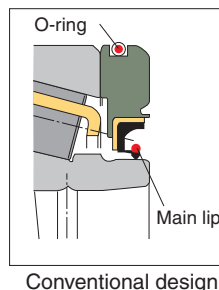
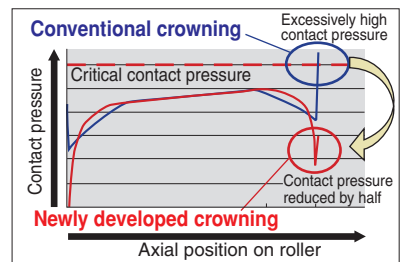
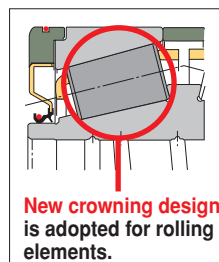
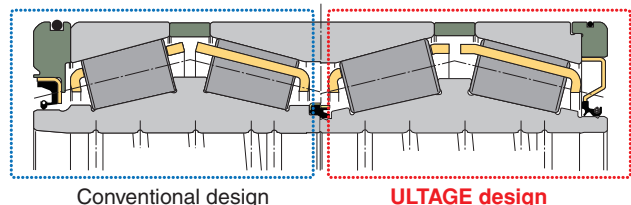

ULTAGE®

"ULTAGE®" (a name created from the combination of "ultimate," signifying refinement, and "stage," signifying NTN's intention that this series of products be employed in diverse applications) is the general name for NTN's new generation of bearings that are noted for their industry-leading performance.

Metric series Tolerances [JIS 0 Class]

(1) Inner rings

Unit : μm

Nominal bore diameter d mm		Dimensional tolerance of mean bore diameter within plane Δd_{mp}		Bore diameter variation V_{dp}	Mean bore diameter variation V_{dmp}	Inner ring radial runout K_{ia}	Combination width deviation of 4-row bearings $\Delta_{Bas}, \Delta_{Cis}$	
over	incl.	high	low	max	max	max	high	low
180	250	0	-30	30	23	50	+750	-750
250	315	0	-35	35	26	60	+900	-900
315	400	0	-40	40	30	70	+1 000	-1 000
400	500	0	-45	45	34	80	+1 200	-1 200
500	630	0	-50	50	38	90	+1 200	-1 200
630	800	0	-75	75	56	105	+1 500	-1 500
800	1 000	0	-100	100	75	120	+1 500	-1 500

(2) Outer rings

Unit : μm

Nominal outside diameter D mm		Dimensional tolerance of mean outside diameter within plane ΔD_{mp}		Outside diameter variation V_{Dp}	Mean outside diameter variation V_{Dmp}	Inner ring radial runout K_{ea}
over	incl.	high	low	max	max	max
180	250	0	-30	30	23	50
250	315	0	-35	35	26	60
315	400	0	-40	40	30	70
400	500	0	-45	45	34	80
500	630	0	-50	50	38	100
630	800	0	-75	75	56	120
800	1 000	0	-100	100	75	140

Inch series Tolerances [ABMA 0 Class]

(1) Inner rings

Unit : μm

Nominal bore diameter d mm		Single bore diameter deviation Δds	
over	incl.	high	low
76.2	266.7	+25	0
266.7	304.8	+25	0
304.8	609.6	+51	0
609.6	914.4	+76	0

(2) Outer rings

Unit : μm

Nominal outside diameter D mm		Single outside diameter deviation ΔDs	
over	incl.	high	low
266.7	304.8	+25	0
304.8	609.6	+51	0
609.6	914.4	+76	0

(3) Radial deflection of inner and outer rings

Unit : μm

Nominal outside diameter D mm		Radial runout K_{ia}, K_{ea}
over	incl.	max
266.7	304.8	51
304.8	609.6	51
609.6	914.4	76

(4) Combination width deviation of 4-row bearings

Unit : μm

Nominal bore diameter d mm		Nominal outside diameter D mm		Combination width deviation of 4-row bearings $\Delta_{Bas}, \Delta_{Cis}$	
over	incl.	over	incl.	high	low
101.6	304.8	—	508.0	+1 520	-1 520
304.8	609.6	—	508.0	+1 520	-1 520
304.8	609.6	508.0	—	+1 520	-1 520
609.6	—	—	—	+1 520	-1 520

Dimension Table

(For information about bearing models not listed in the Dimension Table, contact NTN Engineering.)

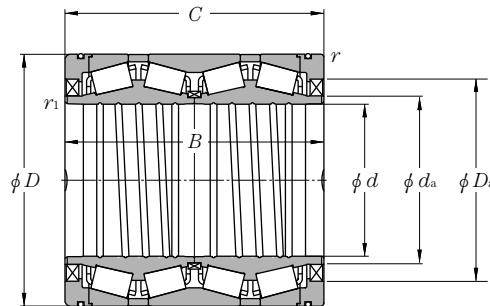

Equivalent radial load dynamic

$$P_r = XF_r + YF_a$$

$\frac{F_a}{F_r} \leq e$		$\frac{F_a}{F_r} > e$	
X	Y	X	Y
1	Y_1	0.67	Y_2

static

$$P_{or} = F_r + Y_0 F_a$$

For values of e , Y_1 , Y_2 and Y_0 see the table below.

Series	Bearing numbers	Boundary dimensions mm						Standard ^② radial clearance (approx.) mm	Standard ^② axial clearance mm
		d	D	B	C	$r_{1s \text{ min}}$ ^①	$r_{2s \text{ min}}$ ^①		
Metric series	CROU-4401LLA1X	220	295	315	315	1	2.5	0.093~0.106	0.420~0.480
	CROU-4501LLA1X	225	320	230	230	1	2.5	0.099~0.115	0.360~0.420
	CROU-4801LLA1X	240	338	248	248	1	2.5	0.104~0.118	0.450~0.510
	CROU-4802LLA1X	240	338	340	340	1	2.5	0.107~0.123	0.400~0.460
	CROU-5001LLA1X	250	365	270	270	1	2.5	0.113~0.129	0.420~0.480
	CROU-5201LLA1X	260	365	340	340	1	2.5	0.115~0.131	0.430~0.490
	CROU-6001LLA1X	300	420	310	310	1	2.5	0.131~0.147	0.490~0.550
	CROU-6201LLA1X	310	430	350	350	1	2.5	0.136~0.154	0.520~0.590
	CROU-8201LLA1X	410	546	400	400	1.5	2.5	0.173~0.188	0.780~0.850
	CROU-8801LLA1X	440	590	480	480	1.5	2.5	0.188~0.204	0.850~0.920
	CROU-8802LLA1X	440	620	454	454	3	2.5	0.195~0.211	0.880~0.950
	CROU-10601LLA1X [※]	530	780	570	570	3	2.5	0.244~0.259	1.100~1.170
Inch series	CROU-4402LLA1X	220.662	314.325	239.712	239.712	1	2.5	0.098~0.111	0.450~0.510
	CROU-5101LLA1X	254.000	358.775	269.875	269.875	1	2.5	0.111~0.127	0.430~0.490
	CROU-6101LLA1X	304.902	412.648	266.700	266.700	1	2.5	0.130~0.150	0.450~0.520
	CROU-6901LLA1X	343.052	457.098	254.000	254.000	1	2.5	0.136~0.158	0.430~0.500
	CROU-6902LLA1X	343.052	457.098	299.000	299.000	1	2.5	0.143~0.163	0.500~0.570
	CROU-10001LLA1X [※]	501.650	711.200	520.700	520.700	3	2.5	0.206~0.226	0.730~0.800
	CROU-11901LLA1X	595.312	844.550	615.950	615.950	3	2.5	0.266~0.282	1.200~1.270

① Minimum allowable value of chamfer dimension r . ② Depending on operating conditions, appropriate values may vary. Contact NTN Engineering for technical assistance.

Bearing Number

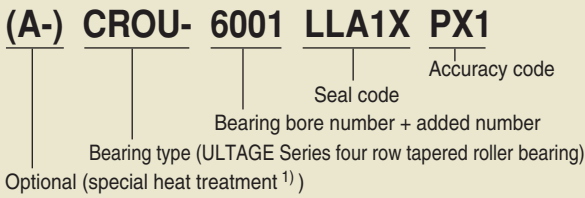

NOTE 1) Carbonitriding

Chamfer Dimension

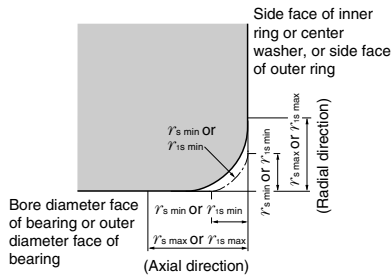

Unit : mm

$r's \text{ min}$ or $r'is \text{ min}$	Nominal bore diameter d		$r's \text{ max}$ OR $r'is \text{ max}$	
	over	incl.	Radial direction	Axial direction
1	50	—	1.9	3
1.5	120	250	2.8	3.5
	250	—	3.5	4
2.5	120	250	4	5.5
	250	—	4.5	6
3	120	250	4.5	6.5
	250	400	5	7
	400	—	5.5	7.5

Operating Temperature Range

- 20 to +120°C

Fit (recommended)

- Metric series: Shaft d6/ Housing G7
- Inch series: Contact NTN Engineering for technical assistance.

Standard Prelubricating Grease

- Brand: Kyodo Yushi Palmax RBG (L373)
- Fill amount: Space volume ratio 35%

Limiting Speed

- $dm \cdot N \leq 30 \times 10^4$

dm : bearing center diameter (mm) = $(d + D) / 2$

d : bearing bore diameter (mm)

D : bearing outside diameter (mm)

N : running speed (min⁻¹)

The values above are shown as a guide, and may not be met under certain operating conditions. For details, contact NTN Engineering.

Materials

- Inner and outer rings: Case hardening steel
- Rolling element: Bearing steel
- ※ mark only: Case hardening steel

dynamic C_R	Basic load ratings				Abutment and fillet dimensions		Constant e	Axial load factor		
	static C_{0r}	dynamic C_R	static C_{0r}	dynamic C_R	d_a	D_a		Y_1	Y_2	Y_0
1 880	4 650	192 000	475 000	235	267	0.33	2.03	3.02	1.98	
1 870	3 700	190 000	375 000	241	294	0.41	1.64	2.44	1.6	
2 320	4 600	236 000	470 000	259	309	0.35	1.95	2.90	1.91	
2 960	6 850	302 000	700 000	257	299	0.40	1.68	2.50	1.64	
2 760	5 300	280 000	540 000	272	333	0.40	1.68	2.50	1.64	
3 340	7 450	340 000	760 000	275	327	0.40	1.68	2.50	1.64	
3 600	7 650	366 000	780 000	318	382	0.40	1.68	2.50	1.64	
4 020	8 900	410 000	910 000	329	388	0.39	1.72	2.56	1.68	
5 520	13 300	562 000	1 350 000	434	504	0.33	2.03	3.02	1.98	
6 600	16 200	670 000	1 650 000	462	540	0.33	2.03	3.02	1.98	
7 600	16 700	780 000	1 700 000	473	570	0.33	2.03	3.02	1.98	
13 400	29 400	1 370 000	3 000 000	581	710	0.33	2.03	3.02	1.98	
2 240	4 350	228 000	440 000	240	290	0.33	2.07	3.09	2.03	
2 760	5 700	282 000	580 000	274	328	0.39	1.74	2.59	1.70	
2 800	5 850	286 000	600 000	323	379	0.43	1.56	2.32	1.52	
2 820	5 950	288 000	605 000	360	423	0.47	1.43	2.12	1.40	
3 500	8 150	356 000	830 000	364	423	0.43	1.57	2.34	1.53	
10 000	23 900	1 020 000	2 440 000	542	642	0.42	1.60	2.38	1.56	
13 900	33 000	1 420 000	3 350 000	638	770	0.33	2.03	3.02	1.98	

Performance Test Data

Water Resistance Durability Test

[Test conditions]

Bearing number: ULTAGE sealed four row tapered roller bearing CROU-6001LLAX1
 (Dimensions: $\phi 300 \times \phi 420 \times 310$, C_r : 3600 kN, C_{0r} : 7650 kN)
 Prelubricating grease: Palmax RBG
 Radial load: 390 kN ($0.11 C_r$)
 Running speed: Cyclic operation where one cycle consists of
 $\Rightarrow 300 \text{ min}^{-1}$ (0.5 h) $\Rightarrow 500 \text{ min}^{-1}$ (1 h) \Rightarrow
 standstill (1 h)
 Water spray: 0.15 L/min
 Total running hours: 1000 h

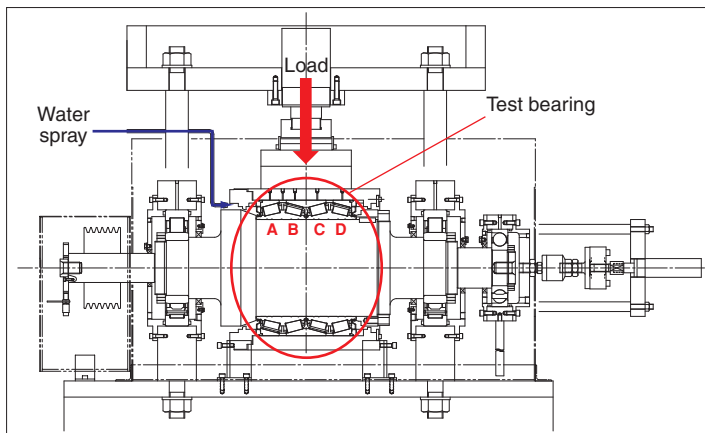

Structure of test rig

[Status of bearing interior after test, and water content in grease (wt%)]

* Water content in factory-fresh grease is in the range of 0.001% to 0.04%.

	Rollers on side A	Outer ring on side B	Outer ring on side C	Rollers on side D	Outer ring on side D
Conventional seal	 0.27%	 0.03%	 2.01%	 0.03%	 0.04%
High sealing seal	 0.03%	 0.02%	 0.02%	 0.03%	 0.02%



Appearance of test rig

Evidence of water intrusion is found on the conventional seal. In contrast, the NTN "high sealing" seal does not exhibit evidence of water intrusion.

Life test result

[Test conditions]

Bearing number: Comparison of conventional design and ULTAGE in terms of life 30316U
 (dimensions: $\phi 80 \times \phi 170 \times 42.5$)
 Lubrication: Turbine Oil VG68, circulating lubrication
 Combined radial and axial loads: 117 kN/bearing
 ($0.4 C_r$ equivalent, radial load: 75 kN/bearing, axial load: 50 kN/bearing)
 Running speed: 2000 min^{-1}
 Misalignment: 1/600 (0.1°)

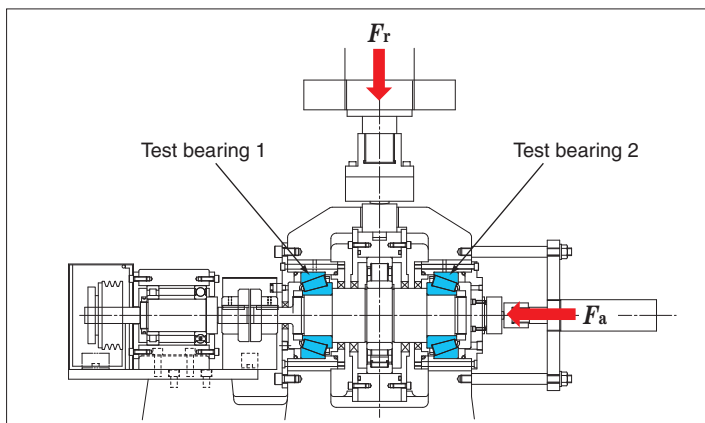

Structure of test rig

[Test result]

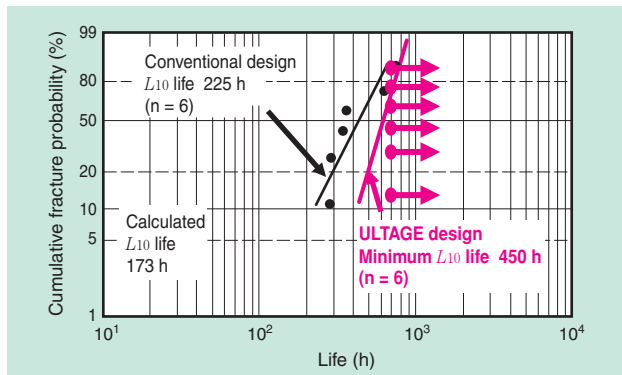

	Appearance of assembled inner ring	Appearance of outer ring	Status
Conventional design	 Flaking	 Flaking	Flaking occurred near the chamfered end of rollers as well as at the corresponding contact point on the outer ring. ($L_{10} = 225 \text{ h}$)
ULTAGE	 No damage	 No damage	After termination of the test at 690 hours, the test bearing was free from any failures including flaking.

ULTAGE bearings boast a life 2.6 times as long as their design life, and twice as long as the life of conventional bearings, when both bearing types are tested under test conditions of $0.4 C_r$ and 1/600 misalignment.