

## Specialized Plummer Block

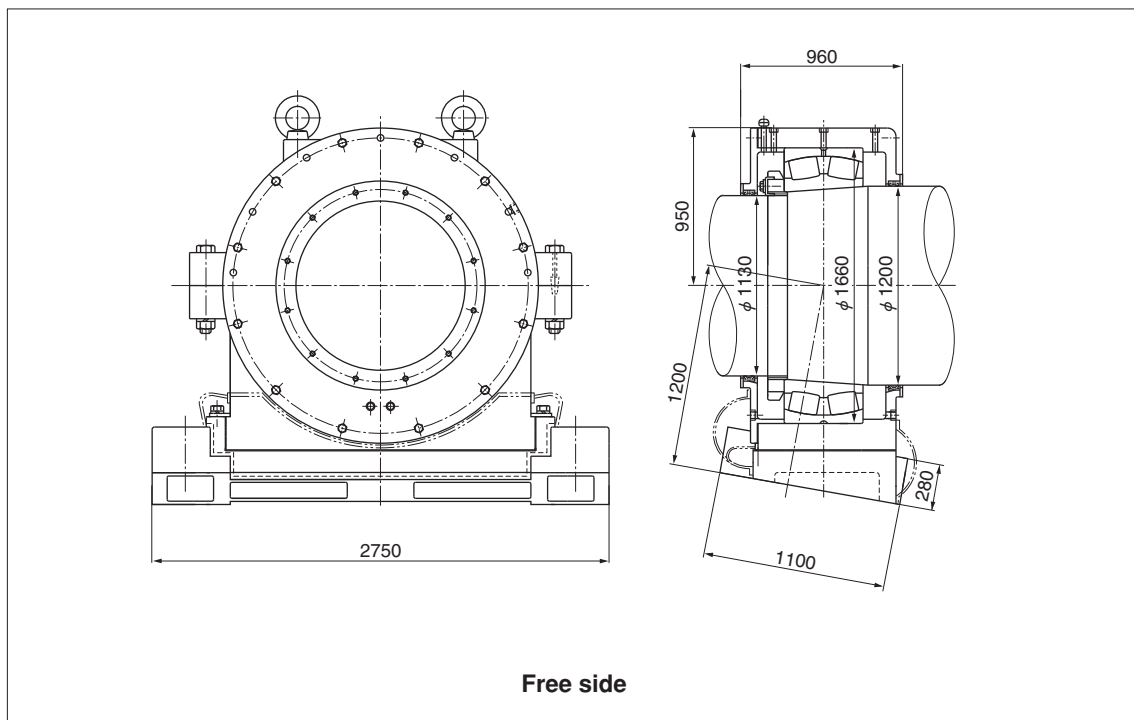

<b>Number</b>	Fixed side: 0S23601GN1Y545ZX1 Free side: 0S23602N1Y545ZX1
<b>Bearing</b>	240/1180BK30
<b>Application</b>	Tube dryer
<b>Shaft speed</b>	6~12min <sup>-1</sup>
<b>Lubricating system</b>	Circulating oil

Specialized Plummer Block

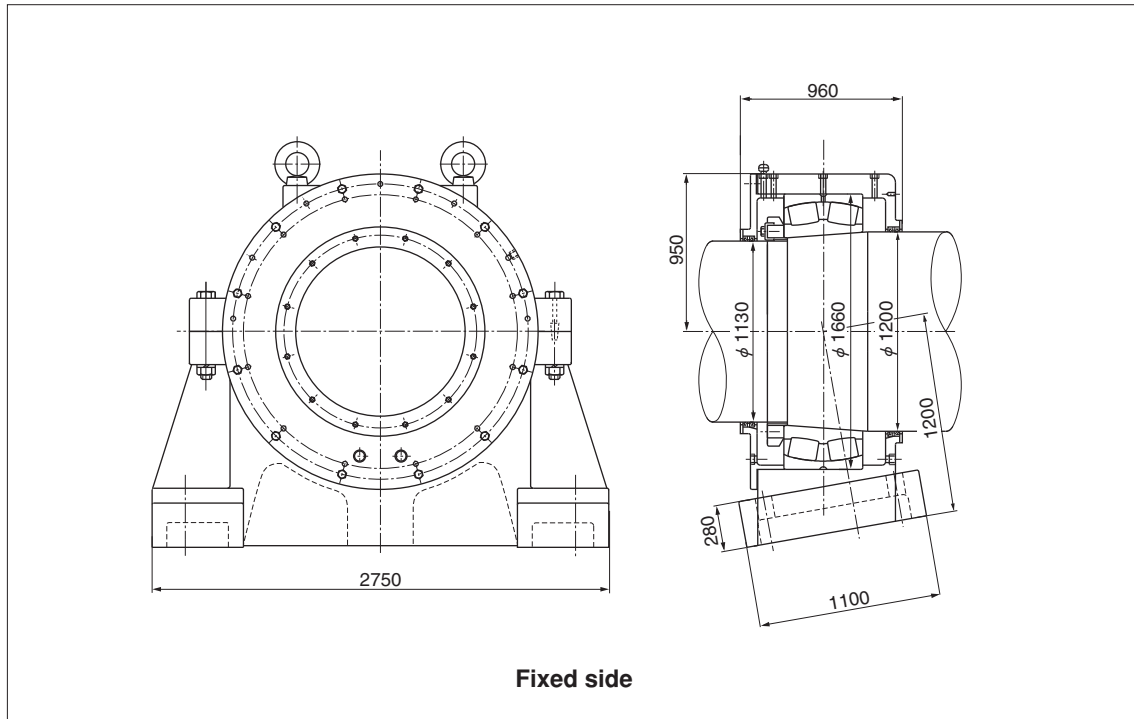
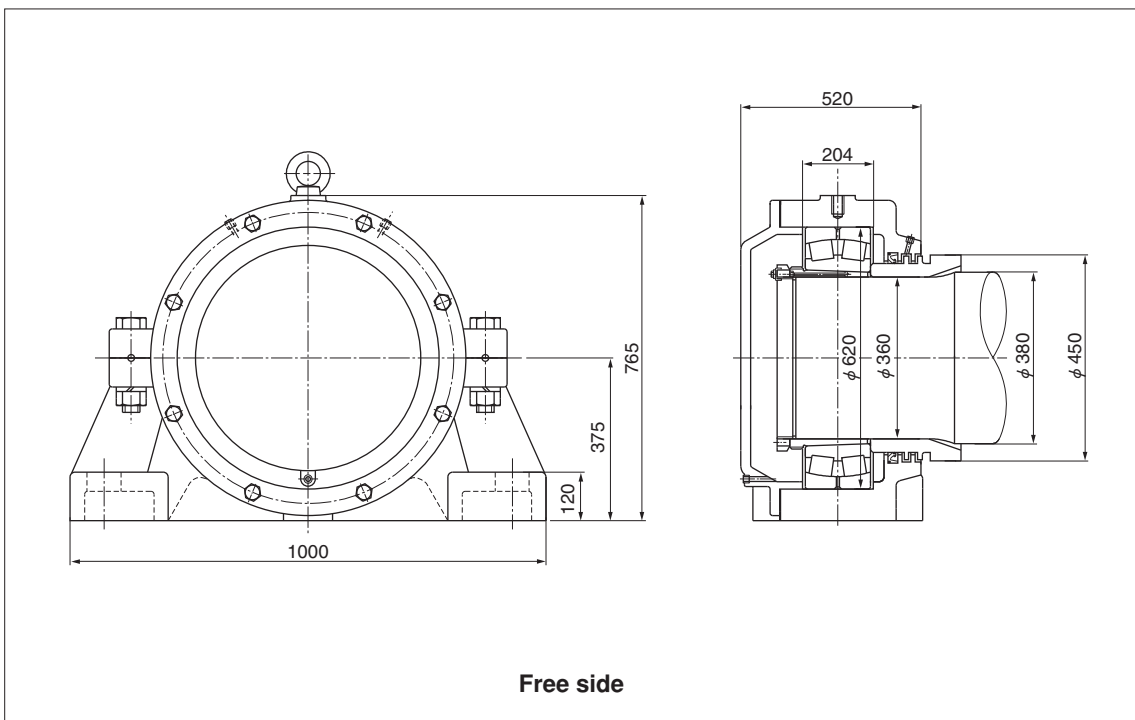
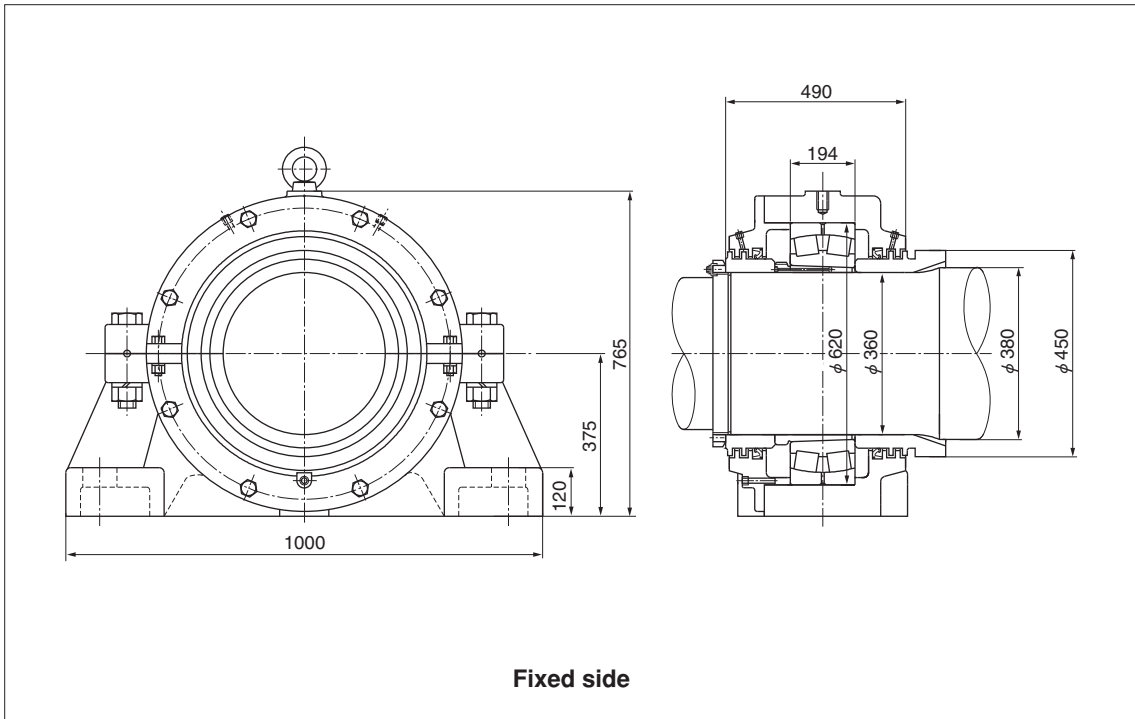

<b>Number</b>	Fixed side: 1S7642GY851ZX1 Free side: 1S7642M1Y851ZX1
<b>Bearing</b>	23176BK+AH3176H
<b>Application</b>	Sintering m
<b>Shaft speed</b>	3~4min <sup>-1</sup>
<b>Lubricating system</b>	Grease lubrication

## Specialized Plummer Block

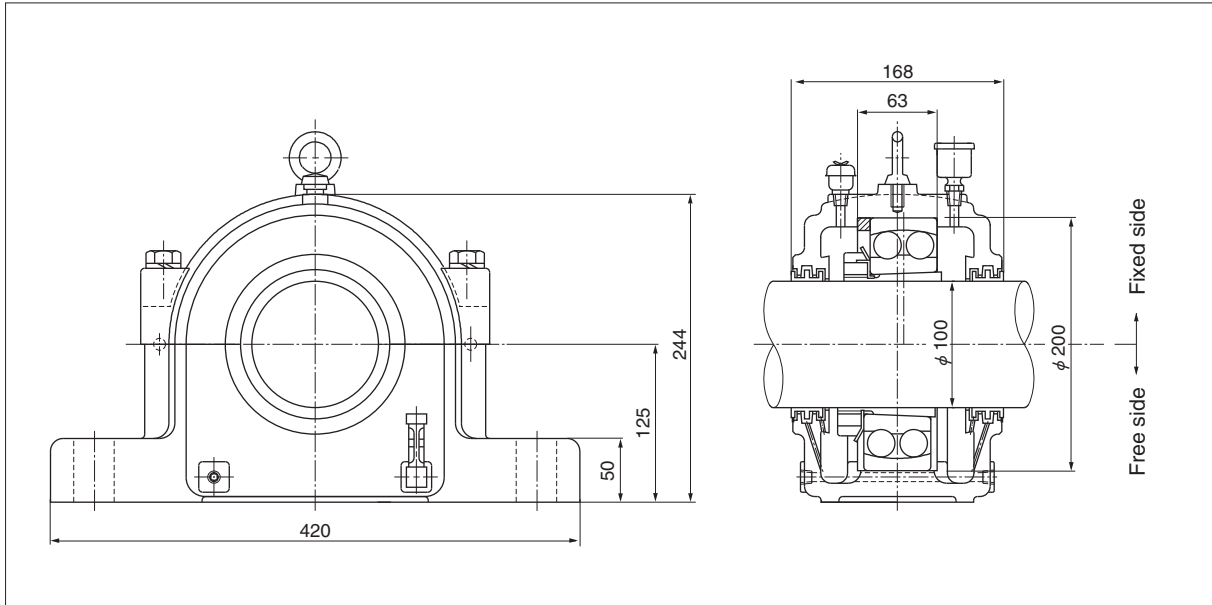

<b>Number</b>	Fixed side: 2S22B32GX1 Free Side: 2S22B32
<b>Bearing</b>	2222SKC3+H322X
<b>Application</b>	Pump flywheel
<b>Shaft speed</b>	1 480min <sup>-1</sup>
<b>Lubricating system</b>	Oil bath

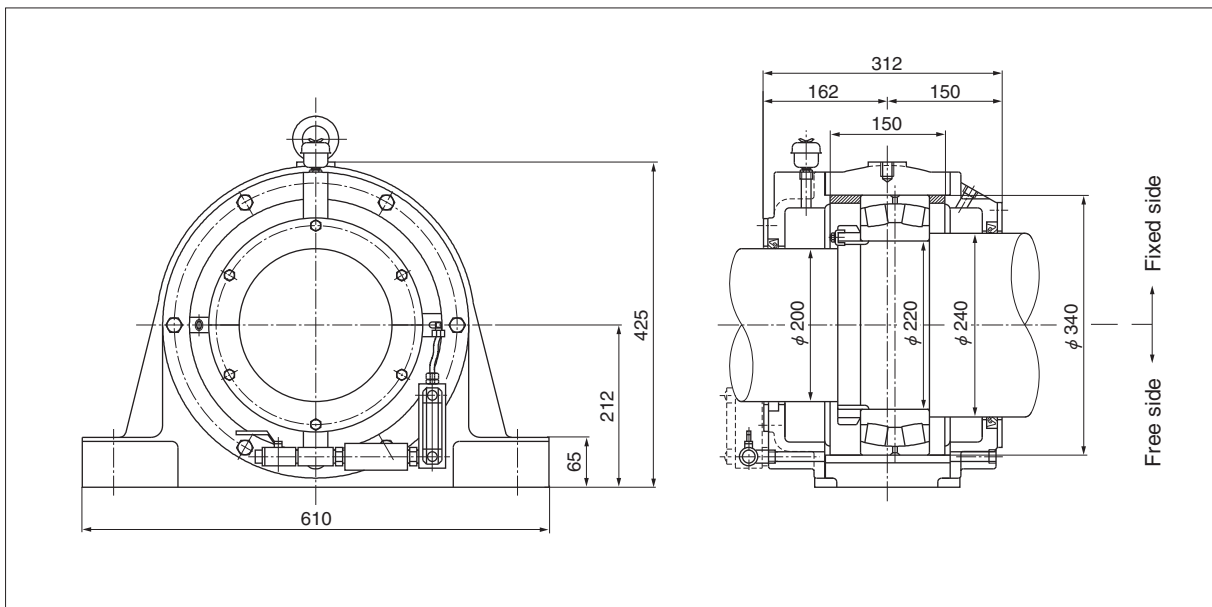

<b>Number</b>	Fixed side: 0S4483Y892GX1ZX1 Free side: 0S4483Y892ZX1
<b>Bearing</b>	TS3-23044BF3C4+ANL44, ALL44
<b>Application</b>	ID dryer
<b>Shaft speed</b>	8min <sup>-1</sup> (MAX)
<b>Lubricating system</b>	Oil bath

Specialized Plummer Block

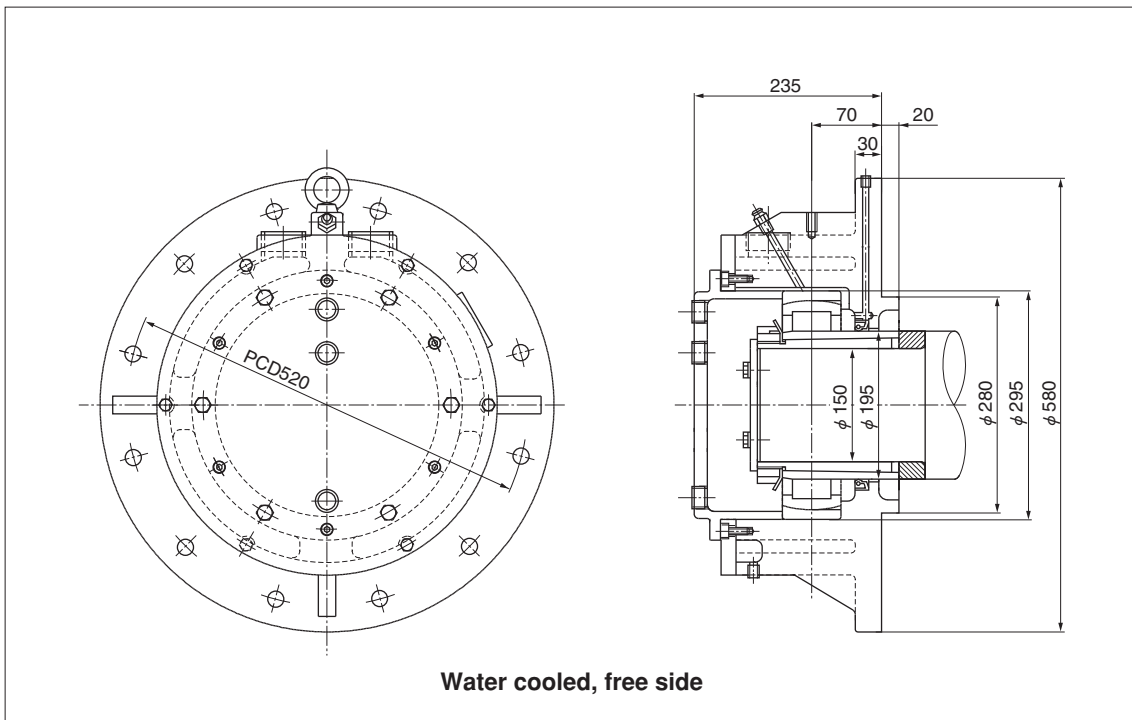
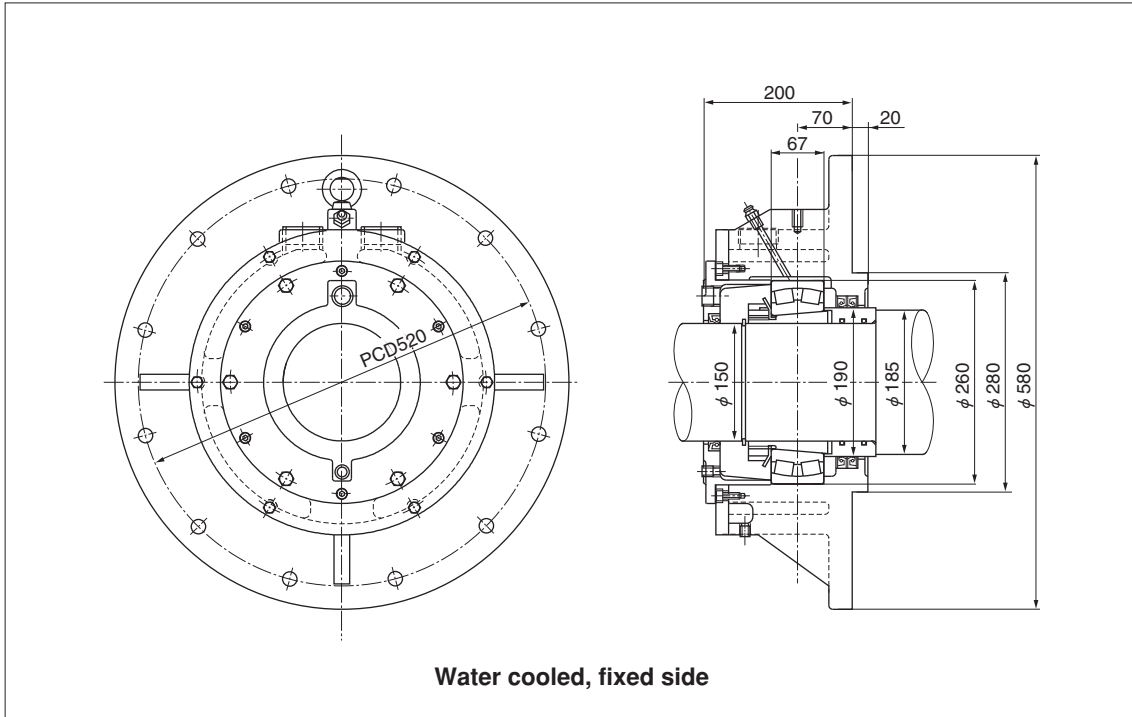

<b>Number</b>	Fixed side: FY3475GY133ZX1 Free side: FY3460M1Y133ZX1
<b>Bearing</b>	Fixed side: TS3-23034BKC4+H3034 Free side: TS2-R3431K30C4+H9180
<b>Application</b>	CAPL
<b>Shaft speed</b>	90min <sup>-1</sup>
<b>Lubricating system</b>	Grease lubrication