

# LINEAR BEARINGS

## LINEAR BALL BEARINGS:

Drawn Cup, Solid, Stroke, Linear Flat Roller,  
and Linear Roller Bearing Types

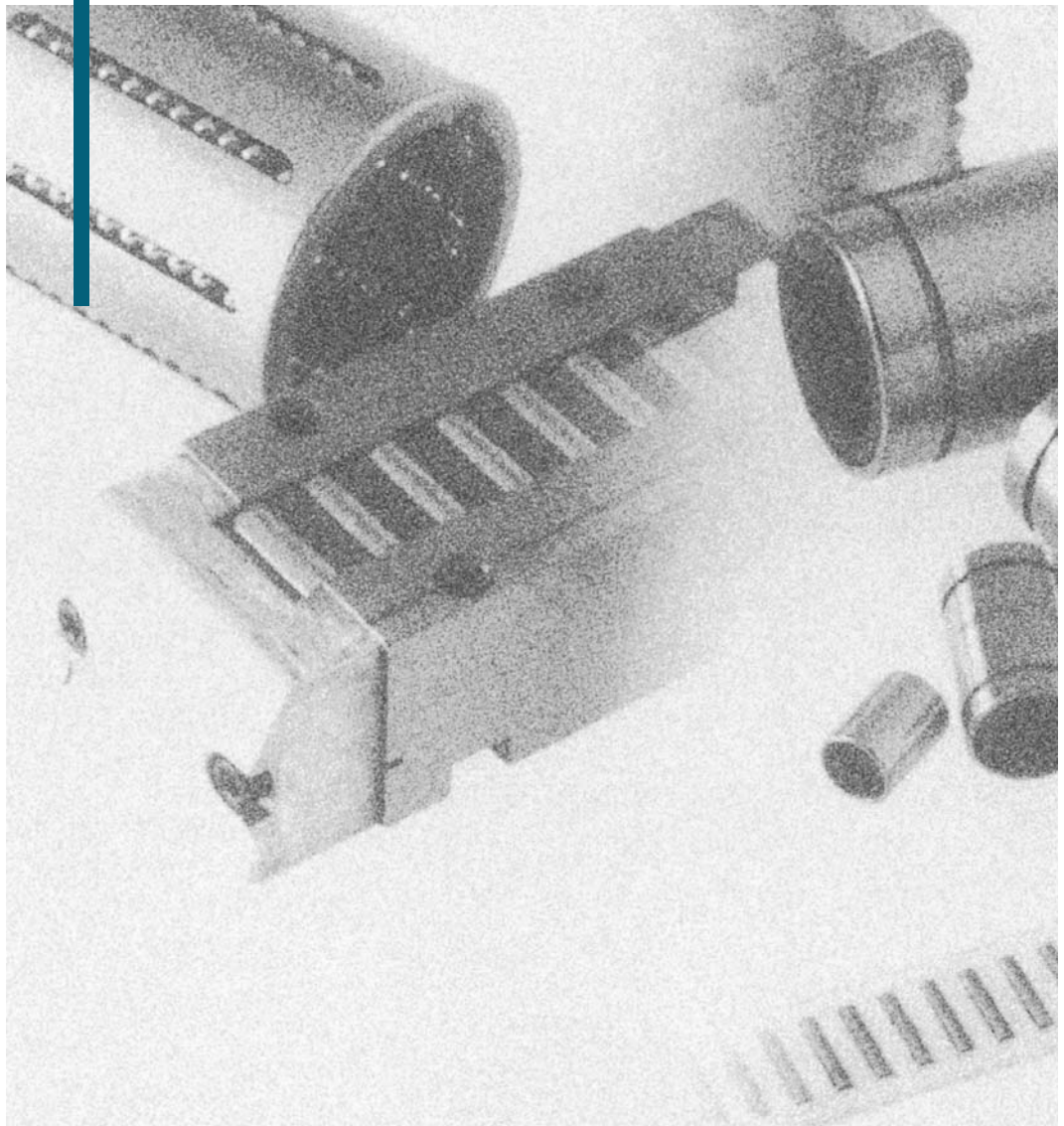

## Linear Ball Bearings

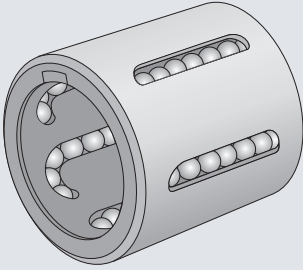
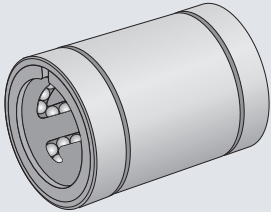
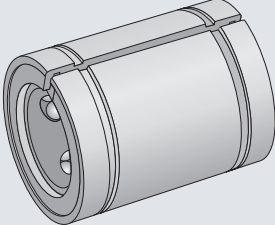
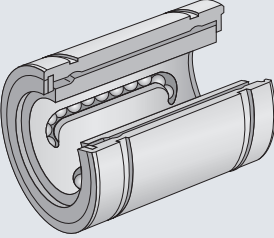
Type	Applicable shaft diameter (mm)	Composition of bearing number
<p><b>KH</b></p> 	<p>This type is composed of an outer ring, steel balls and a cage and the outer ring is cylindrical similarly to that of Type KLM and drawn from a steel plate by precision deep drawing, then enabling to design a compact bearing construction of low section and lightweight. This type also ensures precise and smooth infinite linear motion similarly to other types.</p> <p><math>\phi 6 - \phi 50</math></p> <p>With seal <math>\phi 10 - \phi 50</math></p>	<p><b>KH 20 30 LL/3AS</b></p> <ul style="list-style-type: none"> <li>— Suffix</li> <li>— LL: Seal</li> <li>— 3AS: Grease code</li> <li>— Width</li> <li>— Roller set bore diameter</li> <li>— Type code</li> </ul>
<p><b>KLM</b></p> 	<p>This type composed of an outer ring, steel balls and a cage is a cylindrical bearing for the most universal applications, which ensures precise and smooth infinite linear motion due to its outer ring of high rigidity.</p> <p><math>\phi 3 - \phi 40</math></p>	<p><b>KLM 06 LL/3AS</b></p> <ul style="list-style-type: none"> <li>— Suffix</li> <li>— LL: Seal</li> <li>— 3AS: Grease code</li> <li>— Roller set bore diameter</li> <li>— Type code</li> </ul>
<p><b>KLM · · S</b></p> 	<p>This type is composed of an outer ring, steel balls and a cage. And both of the outer ring and the cage have an axial slit, as illustrated, so as to enable to shrink the inscribed circle diameter of the cage by pressing the outer ring in radial direction from the housing and to thereby adjust radial clearance from shaft. Thus, this type also ensures precise and smooth infinite linear motion.</p> <p><math>\phi 16 - \phi 40</math></p>	<p><b>KLM 30 S</b></p> <ul style="list-style-type: none"> <li>— Suffix</li> <li>— S: Clearance-adjustable</li> <li>— Roller set bore diameter</li> <li>— Type code</li> </ul>
<p><b>KLM · · P</b></p> 	<p>This type is composed of an outer ring, steel balls and a cage. And the outer ring and the cage are of arc sectional shape, from which one row of balls (equivalent to 50° to 60° degree spacing) is removed. Thus, the arc cross-sectional ring and cage with 50° to 60° degree opening allows the bearing assy to pass through a shaft support truss or a shaft support stand on midway of the shaft stroke. This type also ensures precise and smooth infinite linear motion, similarly to other types. The bearing radial clearance can be also adjusted.</p> <p><math>\phi 16 - \phi 40</math></p>	<p><b>KLM 30 P LL/3AS</b></p> <ul style="list-style-type: none"> <li>— Suffix</li> <li>— P: Open configuration</li> <li>— LL: Seal</li> <li>— 3AS: Grease code</li> <li>— Roller set bore diameter</li> <li>— Type code</li> </ul>

Components	Infinite motion	Finite motion	Rotating motion	Remarks
Roller set bore diameter: $\phi 20$ Width: 30 Seal: Double-side seal Grease: Prefilled	○	○	×	The cages of the bearing types KLM, KLM, S, KLM,P and KH are all molded from polyamide resin and, therefore, these bearing types shall be used at allowable temperature 120°C and, under continuous running, at 100°C and less.  To avoid deterioration of seal and grease, use a bearing in a temperature range of -20 to 120°C. For continuous machine operation, limit the maximum permissible operating temperature to 100°C.  These bearing types can't rotate.
Roller set bore diameter: $\phi 6$ Seal: Double-side seal Grease: Prefilled	○	○	×	
Roller set bore diameter: $\phi 30$ Type: Clearance-adjustable type	○	○	×	
Roller set bore diameter: $\phi 30$ Type: Open type Seal: Double-side seal Grease: Prefilled	○	○	×	

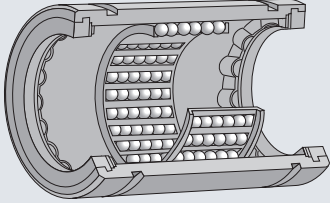
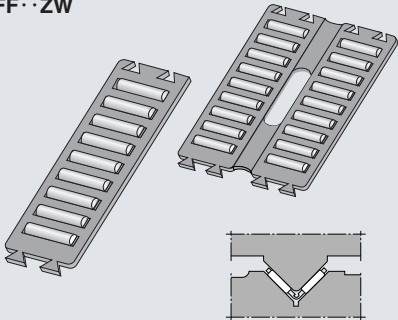
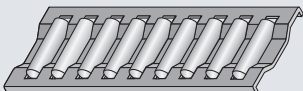
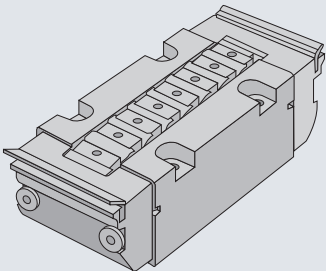
Type	Applicable shaft diameter (mm)	Composition of bearing number
<p><b>KD</b></p> 	<p>This type composed of an outer ring, steel balls and a cage is a cylindrical bearing for the most universal applications, which ensures precise and smooth infinite linear motion due to its outer ring of high rigidity.</p>	<p>Shaft diameter <math>\phi 10 - \phi 80</math></p> <p><b>KD 20 32 45 LL/3AS</b></p> <ul style="list-style-type: none"> <li>— Type code</li> <li>— Roller set bore diameter</li> <li>— Outer diameter</li> <li>— Width</li> <li>— Suffix LL: Seal 3AS: Grease</li> </ul>
<p><b>FF</b> <b>FF · ZW</b></p> 	<p>This type composed of a cage and needle rollers ensures smooth reciprocating motion of less friction actor by being inserted between two planes in relative position. The cage made of polyamide resin is provided with grooved joint at its both ends so several cages can be jointed together into one unit.</p>	<p>Roller diameter <math>\phi 2 - \phi 3.5</math></p> <p><b>FF 25 18 ZW</b></p> <ul style="list-style-type: none"> <li>— Type code</li> <li>— Roller diameter × 10</li> <li>— Width</li> <li>— Suffix ZW: Double row</li> </ul>
<p><b>BF (RF)</b></p> 	<p>This type composed of a cage and needle rollers ensures smooth reciprocating motion of less friction factor by being inserted between two planes in relative position. Press-formed steel plate cage (BF) and polyamide resin cage (RF) are selectively available. However, in the case of this bearing type several bearings can't not be jointed together into one unit.</p>	<p>Roller diameter <math>\phi 3 - \phi 7</math></p> <p><b>BF 30 20 / 1000</b></p> <ul style="list-style-type: none"> <li>— Type code</li> <li>— Roller diameter × 10</li> <li>— Width</li> <li>— Cage overall length</li> </ul>
<p><b>RLM</b></p> 	<p>This type is composed of a track frame, a separator and rollers. This type has the function enabling cylindrical rollers to circulate within the track frame and ensures infinite linear motion on a plane.</p>	<p>Section height 16—38</p> <p><b>RLM 26 × 86</b></p> <ul style="list-style-type: none"> <li>— Type code</li> <li>— Section height</li> <li>— Bearing overall length</li> </ul>

Components	Infinite motion	Finite motion	Rotating motion	Remarks
Roller set bore diameter: $\phi 20$ Outer diameter: f32 Width: 45 Seal: Double-side seal Grease: Prefilled	✕	○	○	To avoid deterioration of seal and grease, use a bearing in a temperature range of -20 to 120°C. For continuous machine operation, limit the maximum permissible operating temperature to 100°C.
Roller diameter: $\phi 2.5$ Width: 18 ZW: Double-row type Number of rows: Two	○	○	✕	Due to its resin cage, this bearing shall be used at allowable temperature 90°C and, under continuous running, at 80°C and less. The double-row type has an elastic joint on the cage center so double rows of flat rollers can be bent to any optional angle along the elastic joint by heating them in oil of 70 to 90°C. By cooling down the double-row rollers with the bent angle held unchanged for several seconds after having bent them to any optional angle, the bent shape of the double rows can be held unchanged so that the double-row rollers can be mounted on a V-shaped surface as illustrated.
Roller diameter: $\phi 3$ Width: 20 Cage length: 1000	○	○	✕	Where the resin cage RF is used, the bearing shall be used at allowable temperature 90°C and, under continuous running, at 80°C and less.  The standard length of the bearing unit with BF cage is 1000 mm. The standard length of the bearing unit with RF cage is 705 mm. Two or more bearings of this type can't be jointed with each other, but it can be supplied at any desired length on request.
Section height: 26 Bearing overall length: 86	○	○	✕	

## Linear Ball Bearings, Drawn Cup and Solid Types

Four to nine rows of balls are configured equally in the outer ring (outer cylinder). The ball rows circulate in axial direction while being guided by the cage. Thus, these bearing types move infinitely on a shaft in axial direction. However, these bearing types can't rotate.

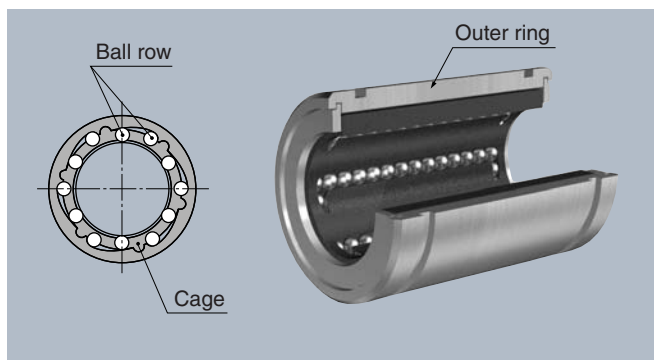

Fig. 1

### Dimensional accuracy

Because of its thin-walled outer ring, the **Type KH** (drawn cup type) unavoidably develops certain degree of deformation in various manufacturing steps, in particular in the heat treatment process. Nevertheless, this bearing type has been designed so that when press-fitted into a housing of accurate dimensions, its deformation is corrected and it can restore its original accuracy to fully develop its design functions. For a method for determining dimensional accuracy of this bearing, contact **NTN Engineering** for technical assistance.

The dimensional accuracies in boundary dimensions, ball set bore diameter ( $F_w$ ), outside diameter ( $D$ ) and width ( $C$ ) of the **Type KLM** (solid type) are listed in the relevant dimension table. Upon request, **NTN** will supply linear ball bearing products for higher accuracy. For details, contact **NTN Engineering**.

### Bearing fit

By employing a shaft or housing featuring dimensional tolerance in **Table 1** in this page, an appropriate radial internal clearance can be provided in the installed bearing. When a further smaller radial internal clearance is needed, achieve selective fit to obtain an intended radial internal clearance by selecting a relevant bearing-shaft or bearing-housing combination.

Table 1 Bearing fit

Type	Shaft	Housing
series HK Drawn-cup type	h6 (j5)	H7 (H6) - steel series - K7 (K6) - light metal alloy series -
series KLM Solid type	g6 (g5)	H7 (H6)

Note) The parenthesized data is applied to shaft/housing subjected to higher accuracy or of vertical construction.

### Shaft and housing requirements

Any shaft /housing on/in which these bearing types are fitted must meet the requirements specified in **Table 2**.

Table 2 Shaft and housing requirements (recommended)

Characteristics	Shaft	Housing
Roundness (max)	IT3	IT4
Cylindricity (max)	IT2	IT4
Surface roughness (max.)	0.4a	1.6a
Surface hardness	HRC58~64	—
Case depth (min)	0.4mm	—

### How to mount

The **Type KH** (drawn cup) bearing is press-fitted into the housing in interference fit mode: therefore this type of bearing does not need axial positioning with a means such as a snap ring. For press-fitting, force the marking side on the outer ring with a mandrel illustrated in **Fig. 2**.

The **Type KLM** (solid type) cannot be locked to the housing by interference alone. This type of bearing needs to be axially located with a snap ring.

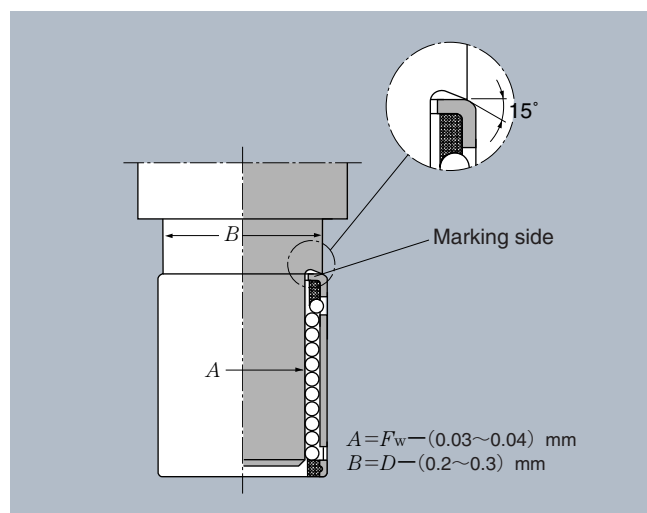
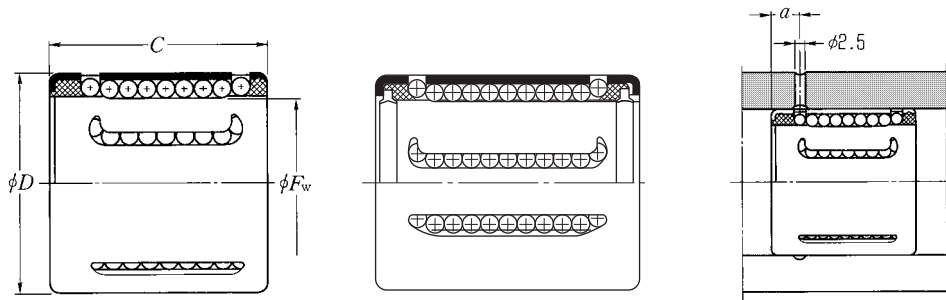

Fig. 2 Series KH

### Accessories

Shafts, shaft support stands and housings exclusive for **NTN** linear ball bearings are also offerable. Feel free to contact **NTN** for the detailed information.

Type KH  
Type KH · LL



With seal

$F_w$  6~50mm

Boundary dimensions				Bearing numbers	Basic load ratings				Number of ball rows	Mass kg (approx.)
mm					dynamic	static	dynamic	static		
$F_w$	$D$	$C$	$a^{1)}$		$C_r$	$C_{or}$	$C_r$	$C_{or}$		
6	12	22	4	KH0622 <sup>2)</sup>	380	225	39	23	4	0.007
8	15	24	5	KH0824 <sup>2)</sup>	420	255	43	26	4	0.012
10	17	26	5	KH1026 <sup>2)</sup>	480	325	49	33	4	0.015
12	19	28	6	KH1228	605	495	62	51	5	0.018
	19	28	6	KH1228LL/3AS	605	495	62	51	5	0.018
14	21	28	6	KH1428	600	505	61	51	5	0.021
16	24	30	7	KH1630	775	600	79	61	5	0.027
	24	30	7	KH1630LL/3AS	775	600	79	61	5	0.027
20	28	30	7	KH2030	1 050	880	107	90	6	0.033
	28	30	7	KH2030LL/3AS	1 050	880	107	90	6	0.033
25	35	40	8	KH2540	1 930	1 560	196	159	6	0.066
	35	40	8	KH2540LL/3AS	1 930	1 560	196	159	6	0.066
30	40	50	8	KH3050	2 700	2 450	275	250	7	0.095
	40	50	8	KH3050LL/3AS	2 700	2 450	275	250	7	0.095
40	52	60	9	KH4060	4 250	4 000	435	410	8	0.18
50	62	70	9	KH5070	5 300	5 700	540	580	9	0.24

Note 1) Showing a-value from the side face with stamped mark thereon.  
2) Imported product from INA, Germany.

Type KLM      Type KLM··LL  
 Type KLM··S    Type KLM··SLL  
 Type KLM··P    Type KLM··PLL

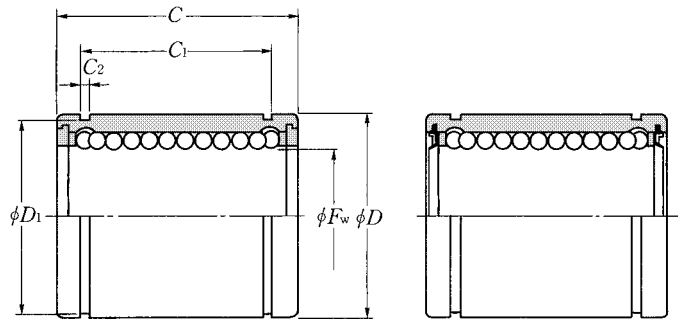

With seal

$F_w$  3~35mm

Boundary dimensions										Basic load ratings				Bearing numbers	Number of ball rows	Mass kg (approx.)
$F_w$	$D$	$C$	mm			$D_1$	$g$	$h$	$\theta$	dynamic		static				
			$C_1$	$C_2$	$\pm 0.240$					N	kgf	$C_r$	$C_{or}$			
3	$7 \begin{smallmatrix} 0 \\ -0.008 \end{smallmatrix}$	$10 \begin{smallmatrix} 0 \\ -0.120 \end{smallmatrix}$	—	—	—	—	—	—	—	51	40	5	4	KLM03	4	0.002
4	$8 \begin{smallmatrix} 0 \\ -0.008 \end{smallmatrix}$	$12 \begin{smallmatrix} 0 \\ -0.120 \end{smallmatrix}$	—	—	—	—	—	—	—	71	52	7	5	KLM04	4	0.003
5	$10 \begin{smallmatrix} 0 \\ -0.009 \end{smallmatrix}$	$15 \begin{smallmatrix} 0 \\ -0.120 \end{smallmatrix}$	—	—	—	—	—	—	—	118	90	12	9	KLM05	4	0.005
6	$12 \begin{smallmatrix} 0 \\ -0.009 \end{smallmatrix}$	$19 \begin{smallmatrix} 0 \\ -0.120 \end{smallmatrix}$	13.3	1.1	11.5	—	—	—	—	130	107	13	11	KLM06	4	0.009
8	$15 \begin{smallmatrix} 0 \\ -0.009 \end{smallmatrix}$	$17 \begin{smallmatrix} 0 \\ -0.120 \end{smallmatrix}$	11.3	1.1	14.3	—	—	—	—	115	94	12	9	KLM08	4	0.012
	$15 \begin{smallmatrix} 0 \\ -0.009 \end{smallmatrix}$	$24 \begin{smallmatrix} 0 \\ -0.120 \end{smallmatrix}$	17.3	1.1	14.3	—	—	—	—	234	188	24	19	KLM08-1	4	0.017
10	$19 \begin{smallmatrix} 0 \\ -0.009 \end{smallmatrix}$	$29 \begin{smallmatrix} 0 \\ -0.120 \end{smallmatrix}$	21.7	1.3	18	—	—	—	—	440	297	45	30	KLM10	4	0.028
12	$22 \begin{smallmatrix} 0 \\ -0.009 \end{smallmatrix}$	$32 \begin{smallmatrix} 0 \\ -0.120 \end{smallmatrix}$	22.7	1.3	21	—	—	—	—	545	455	55	46	KLM12	5	0.042
13	$23 \begin{smallmatrix} 0 \\ -0.009 \end{smallmatrix}$	$32 \begin{smallmatrix} 0 \\ -0.120 \end{smallmatrix}$	22.7	1.3	22	—	—	—	—	540	455	55	46	KLM13	5	0.045
16	28	37	26.5	1.6	27	—	—	—	—	995	805	102	82	KLM16	5	0.075
	$28 \begin{smallmatrix} 0 \\ -0.009 \end{smallmatrix}$	$37 \begin{smallmatrix} 0 \\ -0.120 \end{smallmatrix}$	26.5	1.6	27	0.6	—	—	—	995	805	102	82	KLM16S	5	0.075
	28	37	26.5	1.6	27	—	8.2	60°	—	995	805	102	82	KLM16P	4	0.062
20	32	42	30.3	1.6	30.5	—	—	—	—	1 320	1 150	135	117	KLM20	6	0.10
	$32 \begin{smallmatrix} 0 \\ -0.010 \end{smallmatrix}$	$42 \begin{smallmatrix} 0 \\ -0.120 \end{smallmatrix}$	30.3	1.6	30.5	0.6	—	—	—	1 320	1 150	135	117	KLM20S	6	0.10
	32	42	30.3	1.6	30.5	—	8.6	50°	—	1 320	1 150	135	117	KLM20P	5	0.085
25	40	59	40.7	1.85	38	—	—	—	—	2 560	2 340	261	238	KLM25	6	0.22
	$40 \begin{smallmatrix} 0 \\ -0.010 \end{smallmatrix}$	$59 \begin{smallmatrix} 0 \\ -0.120 \end{smallmatrix}$	40.7	1.85	38	0.6	—	—	—	2 560	2 340	261	238	KLM25S	6	0.22
	40	59	40.7	1.85	38	—	10.8	50°	—	2 560	2 340	261	238	KLM25P	5	0.19
30	45	64	44.2	1.85	43	—	—	—	—	2 540	2 370	259	241	KLM30	6	0.26
	$45 \begin{smallmatrix} 0 \\ -0.010 \end{smallmatrix}$	$64 \begin{smallmatrix} 0 \\ -0.120 \end{smallmatrix}$	44.2	1.85	43	0.6	—	—	—	2 540	2 370	259	241	KLM30S	6	0.26
	45	64	44.2	1.85	43	—	13.0	50°	—	2 540	2 370	259	241	KLM30P	5	0.22
35	52	70	49.2	2.2	49	—	—	—	—	3 650	3 350	375	340	KLM35	6	0.40
	$52 \begin{smallmatrix} 0 \\ -0.012 \end{smallmatrix}$	$70 \begin{smallmatrix} 0 \\ -0.120 \end{smallmatrix}$	49.2	2.2	49	1.2	—	—	—	3 650	3 350	375	340	KLM35S	6	0.40
	52	70	49.2	2.2	49	—	15.1	50°	—	3 650	3 350	375	340	KLM35P	5	0.34



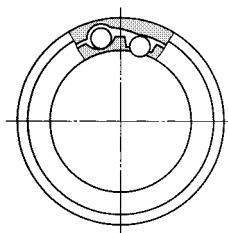

**Type KLM**  
(Standard type)

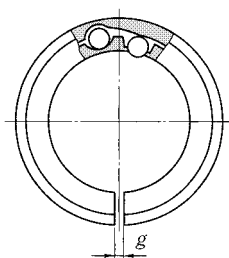

**Type KLM·S**  
(Clearance-adjustable type)

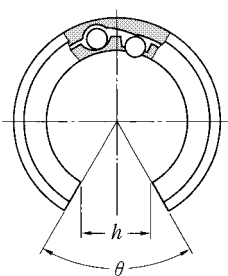

**Type KLM·P**  
(Open type)

$F_w$  40mm

$F_w$	Boundary dimensions									Basic load ratings				Bearing numbers	Number of ball rows	Mass kg (approx.)
	$D$	$C$	mm		$D_1$	$g$	$h$	$\theta$	dynamic	static	dynamic	static				
			$C_1$	$C_2$					N	N	kgf	kgf				
			$\pm 0.300$							$C_r$	$C_{or}$	$C_r$	$C_{or}$			
40	$60_{-0.017}^0$	$80_{-0.120}^0$	60.3	2.1	57	—	—	—	3 950	3 750	400	380	<b>KLM40</b>	6	0.62	
	$60_{-0.017}^0$	$80_{-0.120}^0$	60.3	2.1	57	1.2	—	—	3 950	3 750	400	380	<b>KLM40S</b>	6	0.62	
	$60_{-0.017}^0$	$80_{-0.120}^0$	60.3	2.1	57	—	17.2	50°	3 950	3 750	400	380	<b>KLM40P</b>	5	0.53	

## Linear Ball Bearings, Stroke Type

The bearing cage with multiple ball rows (several balls per row) configured circumferentially therein can move within the outer ring in both circumferential and axial directions. Thus, this bearing type can rotate and reciprocate (but at a limited stroke) on a shaft.

### Bearing construction

Maximum available length of the reciprocal stroke is two times as long as the stroke at which the cage can reciprocate within the outer ring. The outer ring is provided at its both ends with a snap ring acting as a stopper and a wave spring is provided between the snap ring and the cage to damp a shock acting on the cage as well as to prevent wear of the cage.

In addition to the standard type, a special type with synthetic rubber seal (Tail code: **LL**) on the both ends of its outer ring is also available.

### Dimensional accuracy of Bearing

Table 1 the bearing tolerance.

Table 1 Dimensional accuracy

Characteristics	Dimensional tolerance
Ball inscribed circle diameter ( $F_w$ )	F6
Outer ring outer diameter ( $D$ )	h5

### Bearing fit and radial internal clearance

Linear ball bearings need to be used with minimum possible radial internal clearance. In particular, when a linear bearing is used on a vertical shaft or higher accuracy is needed, it is desirable to combine a bearing with a selected shaft and use the bearing-shaft combination with a radial internal clearance in a range of 0 to -5 mm (guideline).

Table 2 shows the bearing fits on shaft and in housing.

Table 2 Bearing fits (recommended)

Operating conditions	Shaft	Housing
Usual operating conditions	k5 (m5)	H6 (H7)
Vertical shaft and high accuracy applications	n5 (p5) ❶	J6 (J7)

❶ Selective fit

### Shaft and housing requirements

Table 3 specifies the requirements for shaft and housing which of the outer surfaces are used as the direct raceway.

Table 3 Shaft and housing requirements (recommended)

Characteristics	Shaft	Housing
Roundness (max)	IT2	IT4
Cylindricity (max)	IT2	IT4
Surface roughness (max)	0.2a	1.6a
Surface hardness	HRC58~64	—
Hardened layer depth (min)	0.4mm	—

### How to mount

This bearing type can't be fixed perfectly to a housing with interference only and, therefore, it is fixed in axial direction using a snap ring. (Refer to Fig. 1)

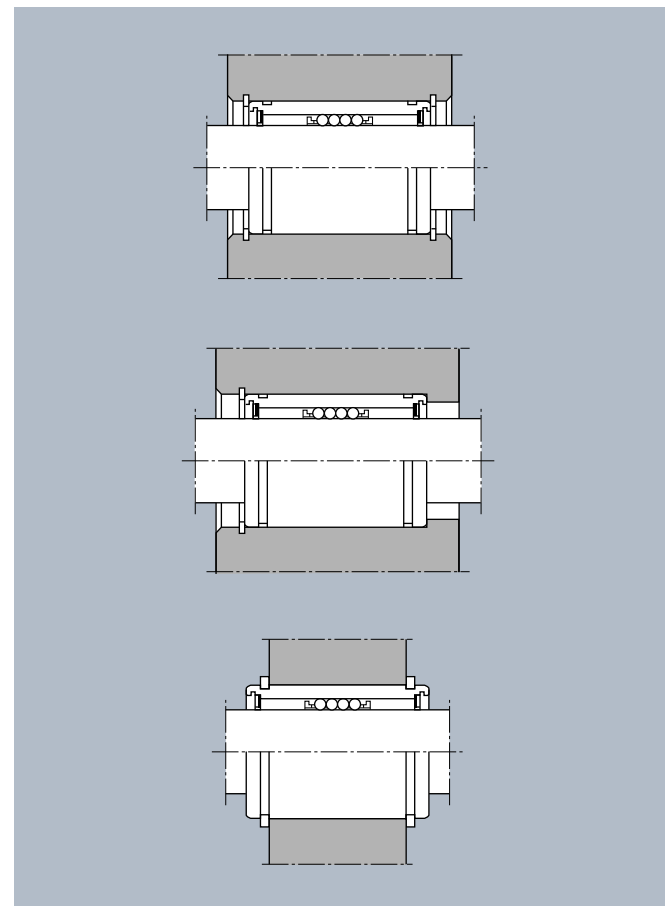

Fig. 1 Axial fixing of bearing

For adjusting the cage so it locates at the outer ring center after a shaft was mounted, push the cage in the arrow direction in **Fig. 2** by inserting the shaft into the outer ring that was press-fitted in the housing. (**Fig. 2**)

In this condition, insert slowly the shaft up to the center point of the reciprocating stroke and, thereafter, further push-in the shaft by 1/2 of the stroke. (**Fig. 3**) Then, return the shaft by 1/2 of the stroke to thereby locate the cage at the outer ring center and the shaft at the center point of the reciprocating stroke. (**Fig. 4**)

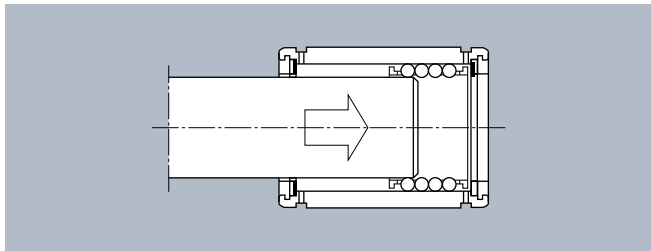

Fig. 2

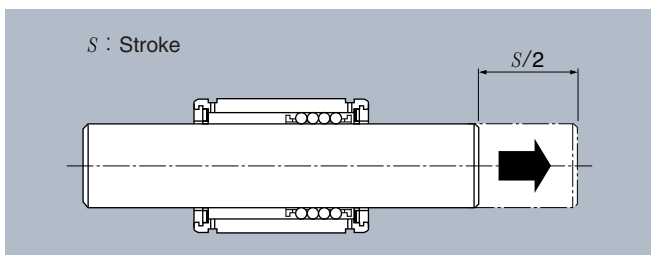

Fig. 3

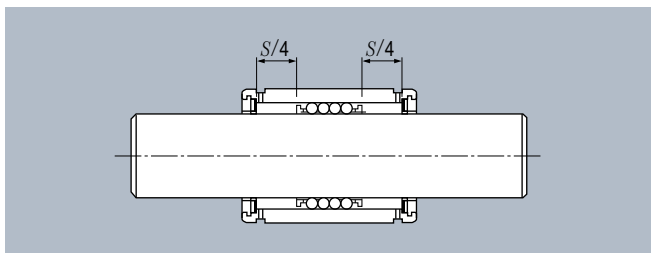
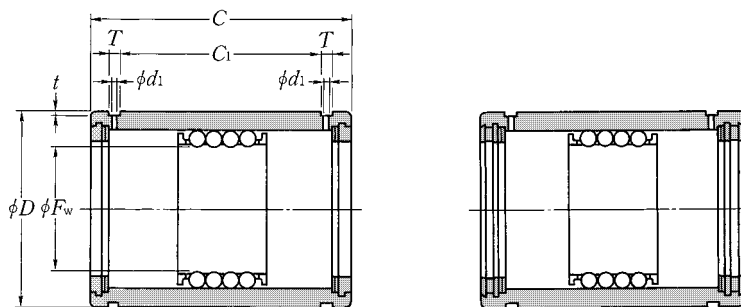

Fig. 4

The outer ring must be press-fitted so its grease feed hole locates at load non-acting side.  
Where moment load acts on a bearing due to use of a vertical shaft, the load could act on the grease feed hole. Caution it.

## Type KD Type KD··LL



**Type KD  
(Open type)**

**Type KD··LL  
(With seal)**

$F_w$  10~80mm

Boundary dimensions mm										Bearing numbers		Basic load ratings				Mass (approx.) kg		
$F_w$	$D$	$C^{1)}$	$T$	$t$	$d_1$	$C_1$	Type KD Max. stroke	Type KD··LL Max. stroke	$C_1$	$C_1$	dynamic N	static kgf	dynamic	static	Type KD	Type KD··LL		
F6	h5										$C_r$	$C_{or}$	$C_r$	$C_{or}$				
10	19	30	1.7	0.4	1.5	22.7	27	15.5	19		KD101930	KD101930LL/3AS	720	535	74	55	0.028	0.030
12	23	32	1.7	0.4	1.5	24.5	30	17.1	22		KD122332	KD122332LL/3AS	920	725	94	74	0.052	0.055
16	28	37	1.7	0.5	1.5	29.1	33	21.1	26		KD162837	KD162837LL/3AS	1 480	1 070	151	109	0.073	0.078
20	32	45	2.2	0.5	2	35.8	55	26.8	46		KD203245	KD203245LL/3AS	1 670	1 230	171	125	0.100	0.105
25	37	45	2.2	0.6	2	35.8	55	26.8	46		KD253745	KD253745LL/3AS	1 890	1 410	192	144	0.115	0.120
30	45	65	2.7	0.7	2.5	53.5	81	45.1	73		KD304565	KD304565LL/3AS	3 800	3 100	390	315	0.265	0.265
35	52	70	2.7	0.7	2.5	58.5	90	50.1	79		KD355270	KD355270LL/3AS	4 200	3 500	430	355	0.405	0.405
40	60	80	2.7	0.7	2.5	68.3	103	59.9	93		KD406080	KD406080LL/3AS	5 900	4 750	600	485	0.635	0.635
45	65	80	2.7	0.7	2.5	68.3	103	59.9	93		KD456580	KD456580LL/3AS	6 400	5 300	655	540	0.675	0.680
50	72	100	3.2	1	3	86.4	136	77.4	125		KD5072100	KD5072100LL/3AS	8 500	6 850	870	695	1.00	1.02
55	80	100	3.2	1	3	86.4	136	77.4	125		KD5580100	KD5580100LL/3AS	9 200	7 550	940	770	1.34	1.36
60	85	100	3.2	1	3	86.4	136	77.4	122		KD6085100	KD6085100LL/3AS	9 900	8 250	1 010	840	1.41	1.43
70	95	100	3.2	1	3	86.4	136	77.4	122		KD7095100	KD7095100LL/3AS	10 600	9 000	1 080	920	1.61	1.63
80	110	100	3.2	1.2	3	86	129	77	116		KD80110100	KD80110100LL/3AS	13 300	10 900	1 350	1 110	2.37	2.40

Note 1) The tolerance for dimension- $C$  is 0, -0.120 mm against  $F_w \leq 50$  mm and 0, -0.150 mm against  $F_w > 50$  mm.



## Linear Flat Rollers

### Linear Flat Rollers

This bearing type composed of a needle roller and flat cage assembly (needle rollers are configured in the flat cage) ensures smooth reciprocating motion with less friction coefficient.

### Types

For **Type FF**, the polyamide resin cage has a dovetail joint groove on its both ends so that several cages can be jointed together into one unit.

For **Type FF·ZW**, two rows of needle rollers are configured in the cage and the cage has an elastic joint on its center so as to enable to bend two rows of flat rollers to any optional angle at the elastic joint by heating them in oil of 70 to 90°C. The two roller rows bent to any optional angle can hold the bent shape unchanged, even under normal operating temperature, by being cooled down for several seconds, with the bending angle held unchanged.

For **Type BF**, the cage is press-formed from steel plate and the standard length of the bearing unit is 1000 mm. For **Type RF**, the cage is of polyamide resin and the standard length of the bearing unit is 705 mm. The both are unavailable for cage to cage inter-jointing, but a bearing unit of any desired length is offerable upon request. Feel free to contact **NTN** for the detailed information.

### Needle roller tolerance

The needle rollers contained in the flat roller cage are manufactured within the dimensional tolerance range of 0 to -2 mm against the nominal diameter ( $D_w$ ).

### Raceway surface requirements

**Table 1** shows the requirements for raceway surface applied to the linear flat roller bearings.

**Table 1 Raceway surface requirements (recommended)**

Characteristics	Tolerance
Surface roughness (max)	0.2a
Surface hardness ①	HRC58~64
Effective hardened layer depth (min)	0.4mm
Mounting accuracy (max) ②	0.1 mm per 1000 mm

① Where raceway surface hardening not allowed, a quenched spring plate may be used.

② Mounting accuracy is expressed with an inclination value in **Fig. 1**.

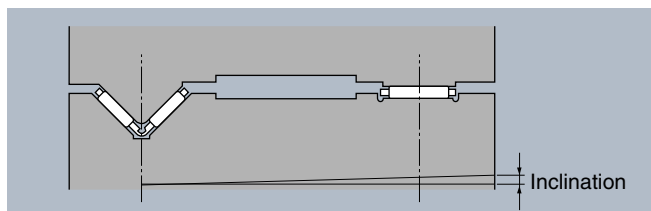
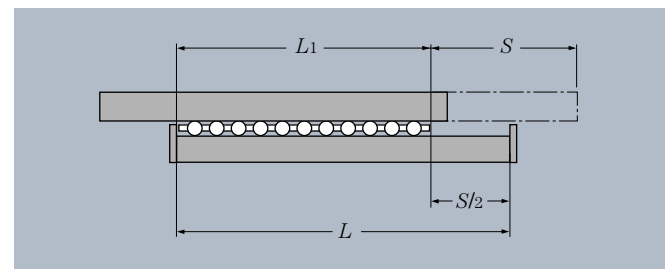

**Fig. 1**

### How to mount

Theoretically the linear flat roller bearing moves by 1/2 of table moving stroke in same direction as the table moving direction. The relationship of bed length ( $L$ ) - stroke ( $S$ ) - cage length ( $L_1$ ) can be expressed in **formula (1)**. (**Fig. 2**)

$$L = S/2 + L_1 \dots\dots\dots (1)$$

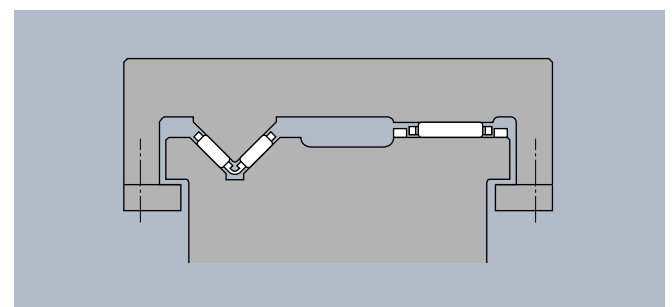

**Fig. 2**

The linear flat roller bearing results in moving deviation due to profile deviation of raceway surface, uneven load or vibration. Therefore, the table or the bed must be equipped with a stopper at its end portion to prevent overrun of the flat roller bearing. (**Fig. 5**)

**Figs. 3 and 4** illustrate application examples of the linear flat roller bearing unit.

If a separate raceway surface having undergone heat treatment and grinding is installed to a machine main body, be careful to avoid deformation of the bearing that can result from tightening.



**Fig. 3 General application**

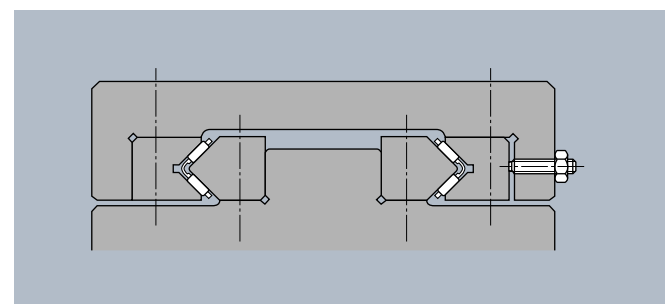

**Fig. 4 When overhung load acts on**

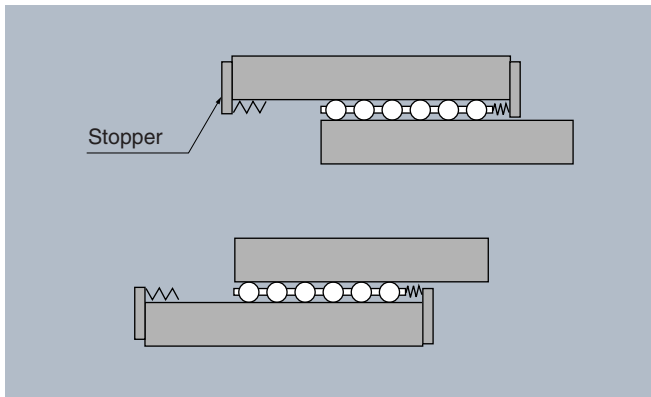
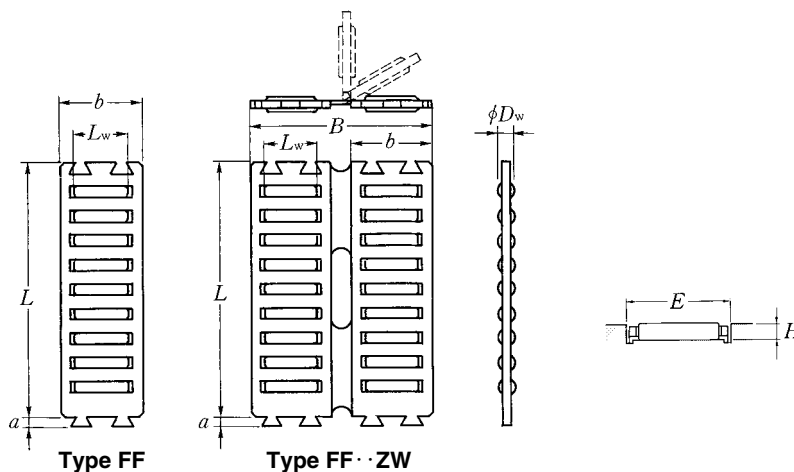

Fig. 5

Type FF  
Type FF··ZW



$D_w$  2~3.5mm

Boundary dimensions						Basic load ratings				Bearing numbers	Number of rolls	Abutment dimensions		Mass kg (approx.)
mm						dynamic	static	dynamic	static			E	H	
$D_w^{1)}$	b	B	L	$L_w$	a	$C_r$ N	$C_{or}$	$C_r$ kgf	$C_{or}$					
2	10	—	32	6.8	2	8 500	19 700	865	2 010	FF2010	7	10.3 <sup>+0.1</sup> <sub>0</sub>	1.7 <sup>0</sup> <sub>-0.2</sub>	0.0020
2	10	25	32	6.8	2	15 500	39 500	1 580	4 000	FF2025ZW	14	25.3 <sup>+0.1</sup> <sub>0</sub>	1.7 <sup>0</sup> <sub>-0.2</sub>	0.0043
2.5	15	—	45	9.8	2.4	17 100	41 400	1 740	4 200	FF2515	8	15.3 <sup>+0.1</sup> <sub>0</sub>	2.2 <sup>0</sup> <sub>-0.2</sub>	0.0038
2.5	15	35	45	9.8	2.4	29 300	82 500	2 980	8 450	FF2535ZW	16	35.3 <sup>+0.1</sup> <sub>0</sub>	2.2 <sup>0</sup> <sub>-0.2</sub>	0.0082
3	20	—	60	13.8	3	31 000	79 500	3 150	8 100	FF3020	9	20.4 <sup>+0.1</sup> <sub>0</sub>	2.7 <sup>0</sup> <sub>-0.2</sub>	0.0089
3	20	45	60	13.8	3	53 500	159 000	5 450	16 200	FF3045ZW	18	45.4 <sup>+0.1</sup> <sub>0</sub>	2.7 <sup>0</sup> <sub>-0.2</sub>	0.019
3.5	25	—	75	17.8	3.2	50 000	132 000	5 100	13 500	FF3525	10	25.4 <sup>+0.1</sup> <sub>0</sub>	3.2 <sup>0</sup> <sub>-0.2</sub>	0.017
3.5	25	55	75	17.8	3.2	86 000	265 000	8 800	27 000	FF3555ZW	20	55.4 <sup>+0.1</sup> <sub>0</sub>	3.2 <sup>0</sup> <sub>-0.2</sub>	0.035

Note 1) The dimensional tolerance for needle roller diameter  $D_w$  is 0 to -2  $\mu$ m.



Type BF  
Type RF

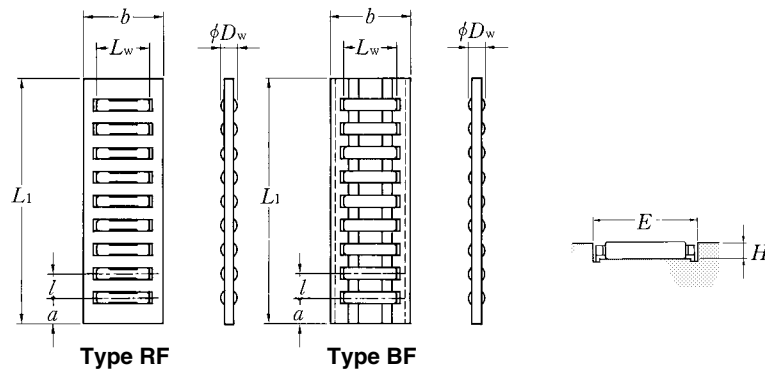

$D_w$  3~7mm

Boundary dimensions						Basic load ratings <sup>3)</sup>				Bearing numbers	Abutment dimensions		Mass <sup>4)</sup>
mm						dynamic	static	dynamic	static		mm		
$D_w^{1)}$	$b$	$L_1^{2)}$	$L_w$	$l$	$a$	$C_r$	$C_{0r}$	$C_r$	$C_{0r}$		$E$	$H$	(approx.)
3	20	705	13.8	6	4.5	34 000	88 500	3 450	9 000	RF3020/705	20.4 <sup>+0.1</sup> <sub>0</sub>	2.7 <sup>0</sup> <sub>-0.2</sub>	0.015
3	20	1 000	15.8	6	5	38 000	102 000	3 850	10 400	BF3020/1000	20.4 <sup>+0.1</sup> <sub>0</sub>	2.7 <sup>0</sup> <sub>-0.2</sub>	0.037
5	23	1 000	19.8	8	8	87 000	211 000	8 850	21 500	BF5023/1000	23.4 <sup>+0.1</sup> <sub>0</sub>	4.7 <sup>0</sup> <sub>-0.2</sub>	0.054
5	32	1 000	27.8	8	8	114 000	299 000	11 600	30 500	BF5032/1000	32.4 <sup>+0.1</sup> <sub>0</sub>	4.7 <sup>0</sup> <sub>-0.2</sub>	0.073
7	28	1 000	24	11	10.5	138 000	305 000	14 000	31 000	BF7028/1000	28.5 <sup>+0.1</sup> <sub>0</sub>	6.7 <sup>0</sup> <sub>-0.2</sub>	0.091
7	35	1 000	30	11	10.5	185 000	445 000	18 900	45 500	BF7035/1000	35.5 <sup>+0.1</sup> <sub>0</sub>	6.7 <sup>0</sup> <sub>-0.2</sub>	0.110

Note 1) The dimensional tolerance for needle roller diameter  $D_w$  is 0 to  $-2 \mu m$ .

2) The standard length  $L_1$  of the cage shall be 1000 mm for Type BF and 705 mm for Type RF.

Where special cage length is required, the nominal bearing number is followed by the numerical length value as exemplified below.

Ex. Where  $L_1 = 500$  mm is required for **BF3020**, **BF302/500**

3) The listed basic load ratings are subject to use of 10 flat rollers. Calculate the basic load ratings for any optional cage length  $L_1$  by the following formula.

$$C = f_1^{7/9} \cdot C_r$$

$$C_0 = f_1 \cdot C_{0r}$$

$$\text{Herein, } f_1 = 0.1 (L_1 + l - 2a) / l$$

4) The listed weights are subject to  $L_1 = 100$  mm.

Remarks: For **Type BF**

1. On occasion, the length of an ordered unit could be shorter by  $l$  dimension shown in each Dimensions Table because the roller and cage assy is cut at the minimum unit of each pocket so as to match the required length.

2. Where this bearing unit is used frequently at various lengths, it is more economical to cut the standard bearing of 1000 mm length to each desired length at your side.

## Linear Roller Bearings

This roller bearing with cylindrical rollers having the function capable of circulating within the raceway block ensures smooth infinite linear motion on a flat surface. The cylindrical rollers are retained and guided by the cage and the ribs of the raceway block.

The cage is of such a construction as not allow adjacent rollers to contact with one another. Hence, the friction coefficient is low.

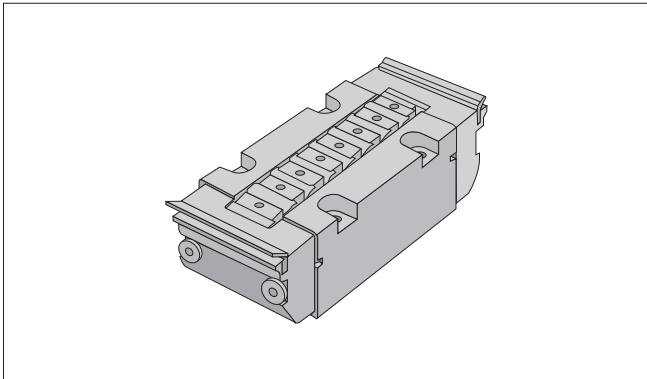

Fig. 1

### Bearing accuracy

All the linear roller bearings are manufactured within the dimensional tolerance range of 0 to  $-2.5\mu\text{m}$  for bearing height ( $H$ ). And these bearings are delivered classified into 5-stepped tolerance classes. (See **Table 1**)

Table 1 Classification of bearing height  $H$  by accuracy class

Unit:  $\mu\text{m}$

Class code	Tolerance for height ( $H$ )
1H	0 ~ -5
2H	-5 ~ -10
3H	-10 ~ -15
4H	-15 ~ -20
5H	-20 ~ -25

### Requirements and tolerances for raceway surface and mounting surface

Table 2 shows the requirements and tolerances for the raceway surface, on which linear roller bearing rolls, and the bearing mounting surface. Where adhesion of a hard foreign matter to the raceway surface is forecast, the raceway surface must be protected with a proper protective cover.

The reference surface for mounting is the back face and opposite face to NTN mark.

Table 2 Requirements for raceway surface and mounting surface (recommended)

Characteristics	Allowable value or tolerance range
Raceway surface roughness (max)	0.2a
Raceway surface hardness	HRC58~64
Effective hardened layer depth of raceway surface (min)	as described in applicable Dimensions Table
Parallelism of mounting surface	
$\Delta x$ (See Fig. 2)	0.05 mm per 100 mm
$\Delta y$ (See Fig. 3)	0.01 mm per 100 mm

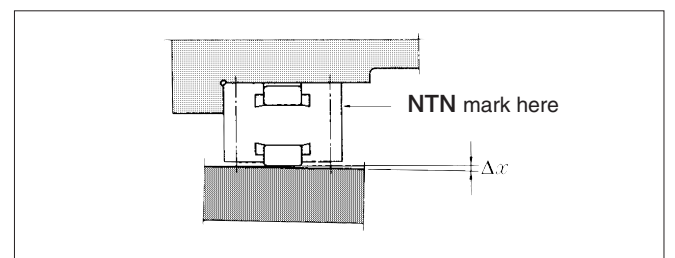

Fig. 2

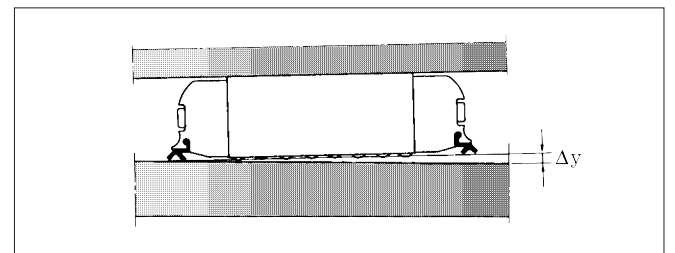

Fig. 3

### How to mount

Fix linear roller bearing using the tapped holes which are provided on the mounting reference surface. (See **Fig. 4**)

If a plurality of bearing units are installed on a same plane, select the units that belong to a same bearing height  $H$  dimensional accuracy class (**Table 1**) so that the load is uniformly distributed onto them.

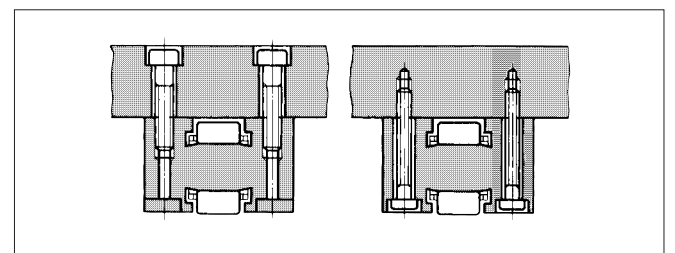
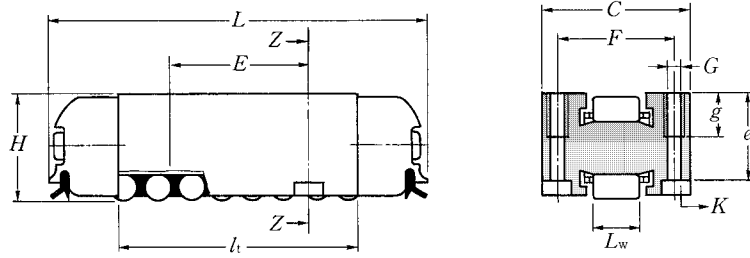

Fig. 4

Type RLM



Section Z-Z

H 16~38mm

Boundary dimensions											Bearing numbers	Basic load ratings				Required case depth on track (min.) mm	Mass kg (approx.)
mm												dynamic	static	dynamic	static		
H	C	L	L <sub>w</sub>	E	F	G	L <sub>t</sub>	e	g	K		N		kgf			
												C <sub>r</sub>	C <sub>or</sub>	C <sub>r</sub>	C <sub>or</sub>		
16	25	62	8	17	19	M4	35.5	12.5	6	φ 3.2	<b>RLM16× 62A</b>	15 400	34 000	1 570	3 450	0.3	0.11
19	27	69	10	25.5	20.6	M4	43.4	15.5	6	φ 3.2	<b>RLM19× 69B</b>	26 100	58 000	2 660	5 900	0.3	0.16
26	40	86	14	28	30	M6	52.4	21	10	φ 4.5	<b>RLM26× 86A</b>	50 000	106 000	5 100	10 800	0.4	0.41
26	40	102	14	44	30	M6	67.9	21	10	φ 4.5	<b>RLM26× 102A</b>	62 500	142 000	6 350	14 400	0.4	0.53
26	40	126	14	68	30	M6	91.8	21	10	φ 4.5	<b>RLM26× 126A</b>	80 000	195 000	8 150	19 900	0.4	0.70
38	52	134	20	51	41	M8	85.7	31	14	φ 6.5	<b>RLM38× 134B</b>	124 000	270 000	12 600	27 500	0.5	1.3